

Fig. 1 CYLINDER BLOCK

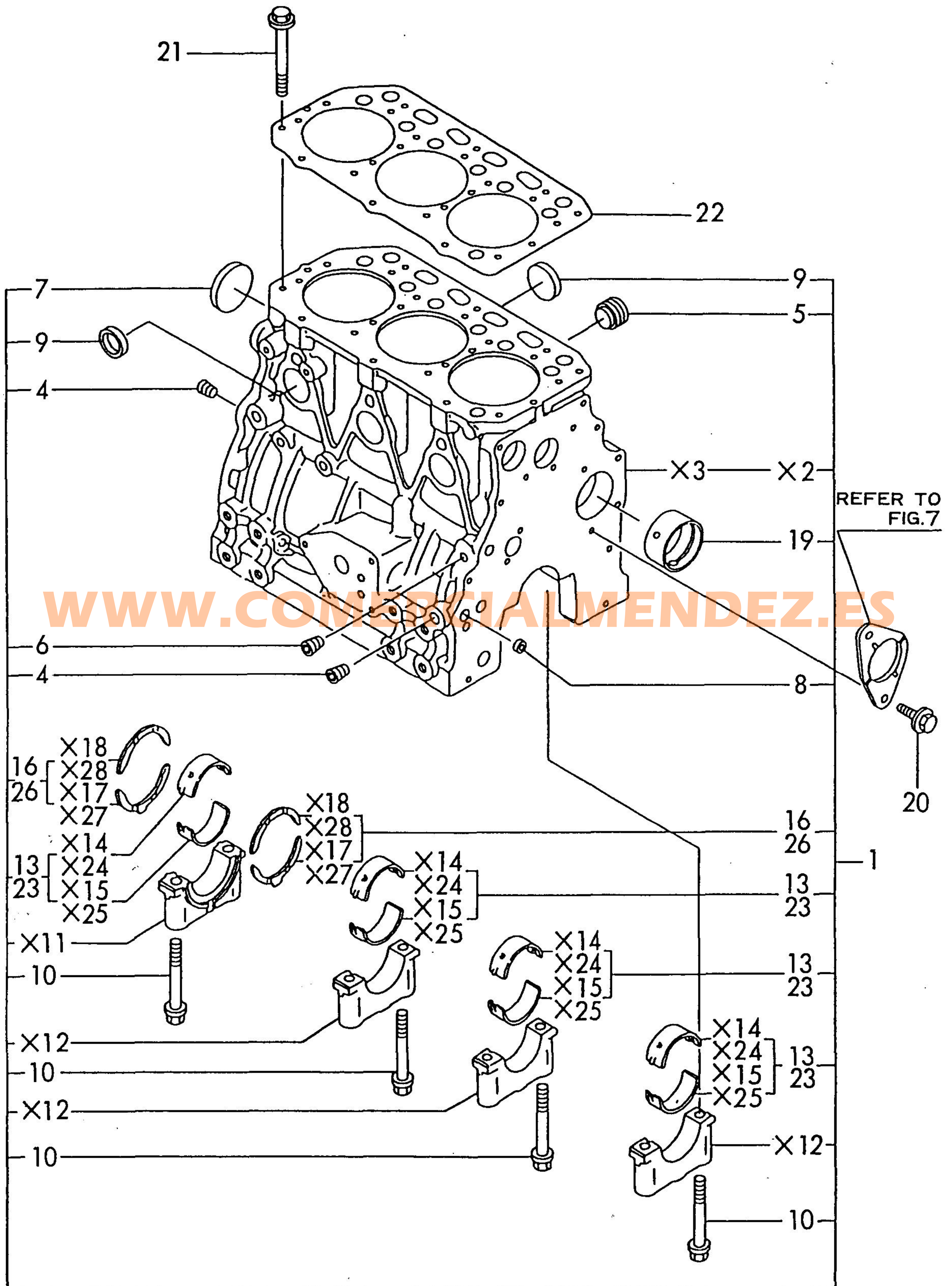
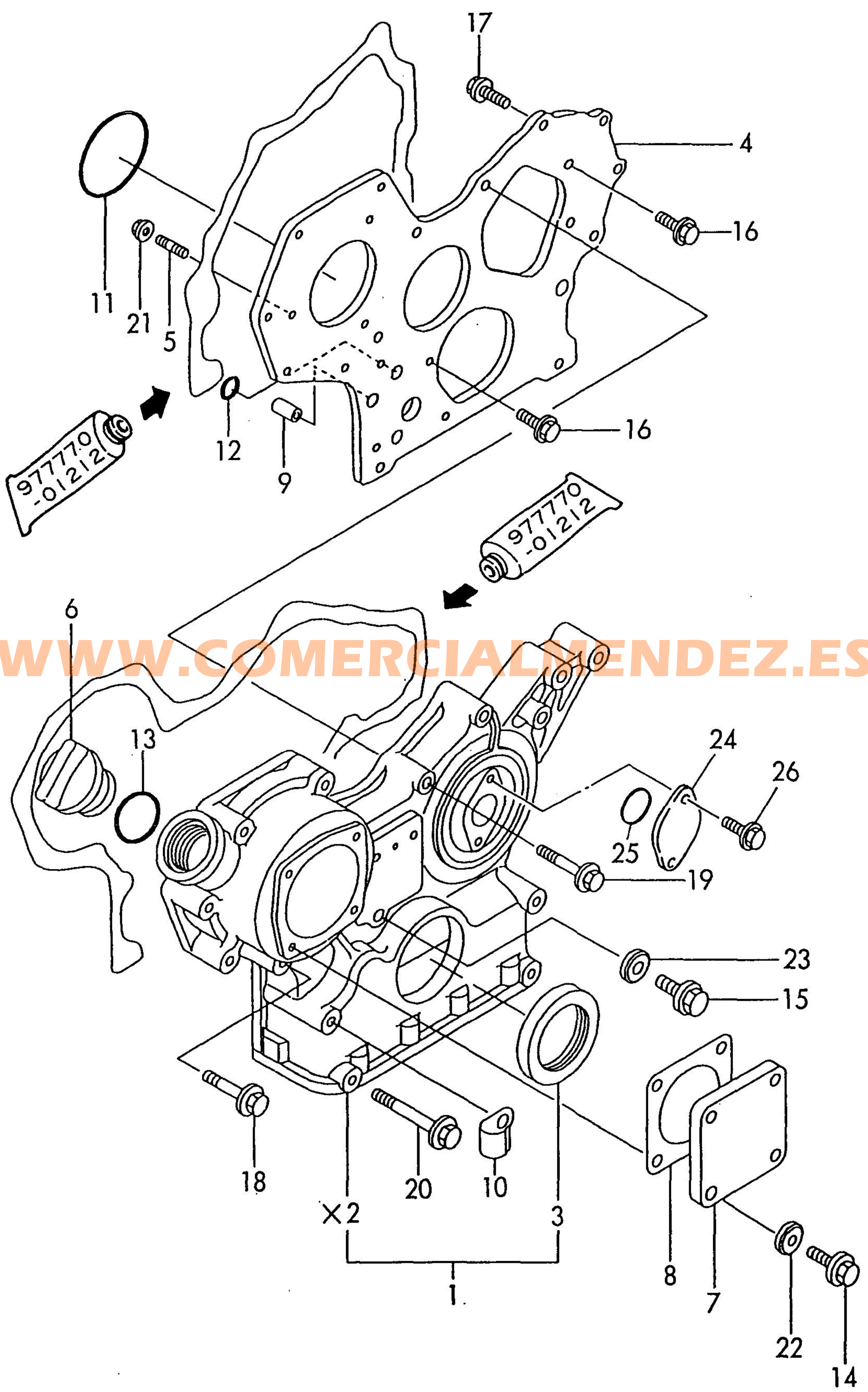

Fig. 2 GEAR HOUSING



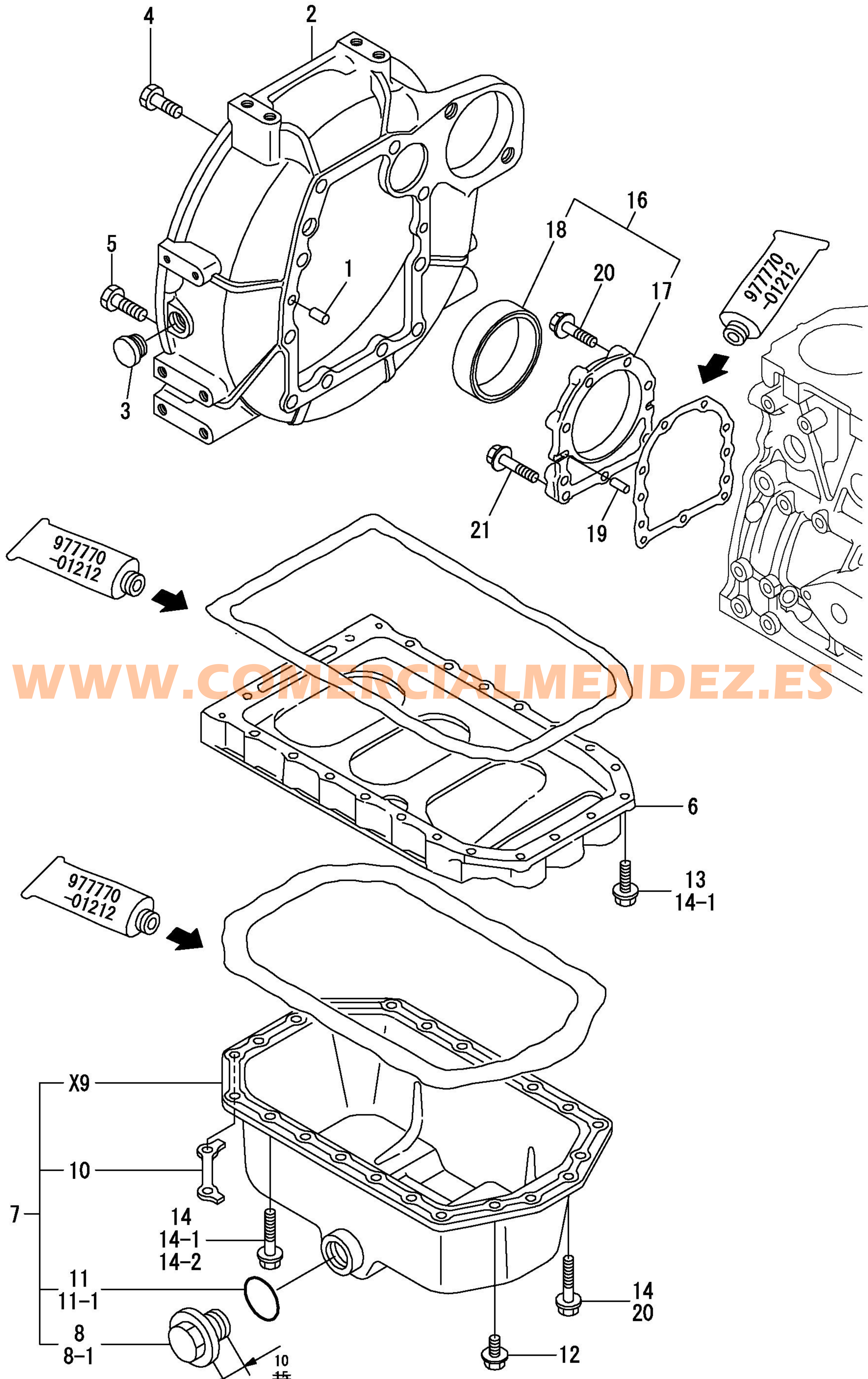

Fig. 4 CYLINDER HEAD & BONNET

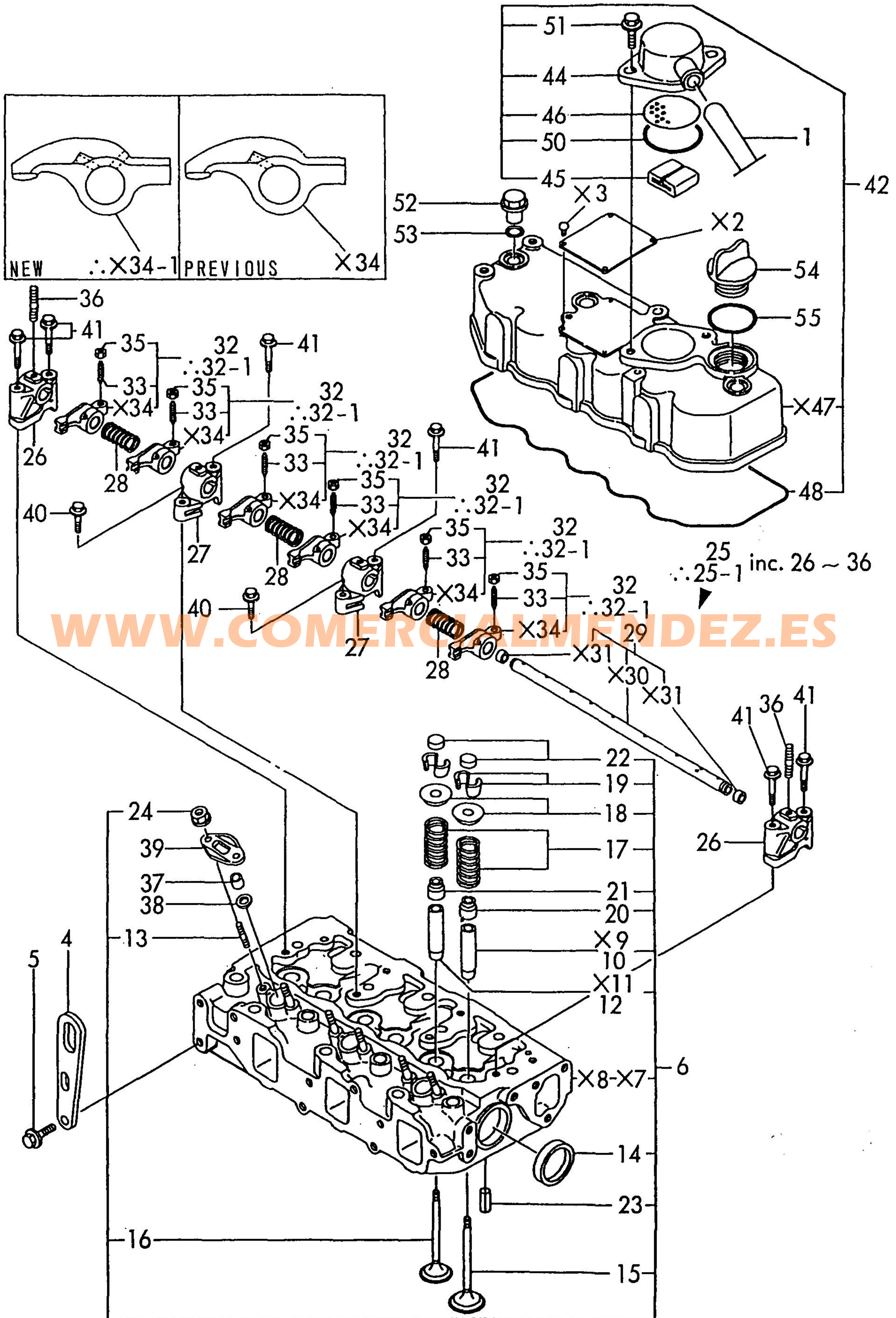
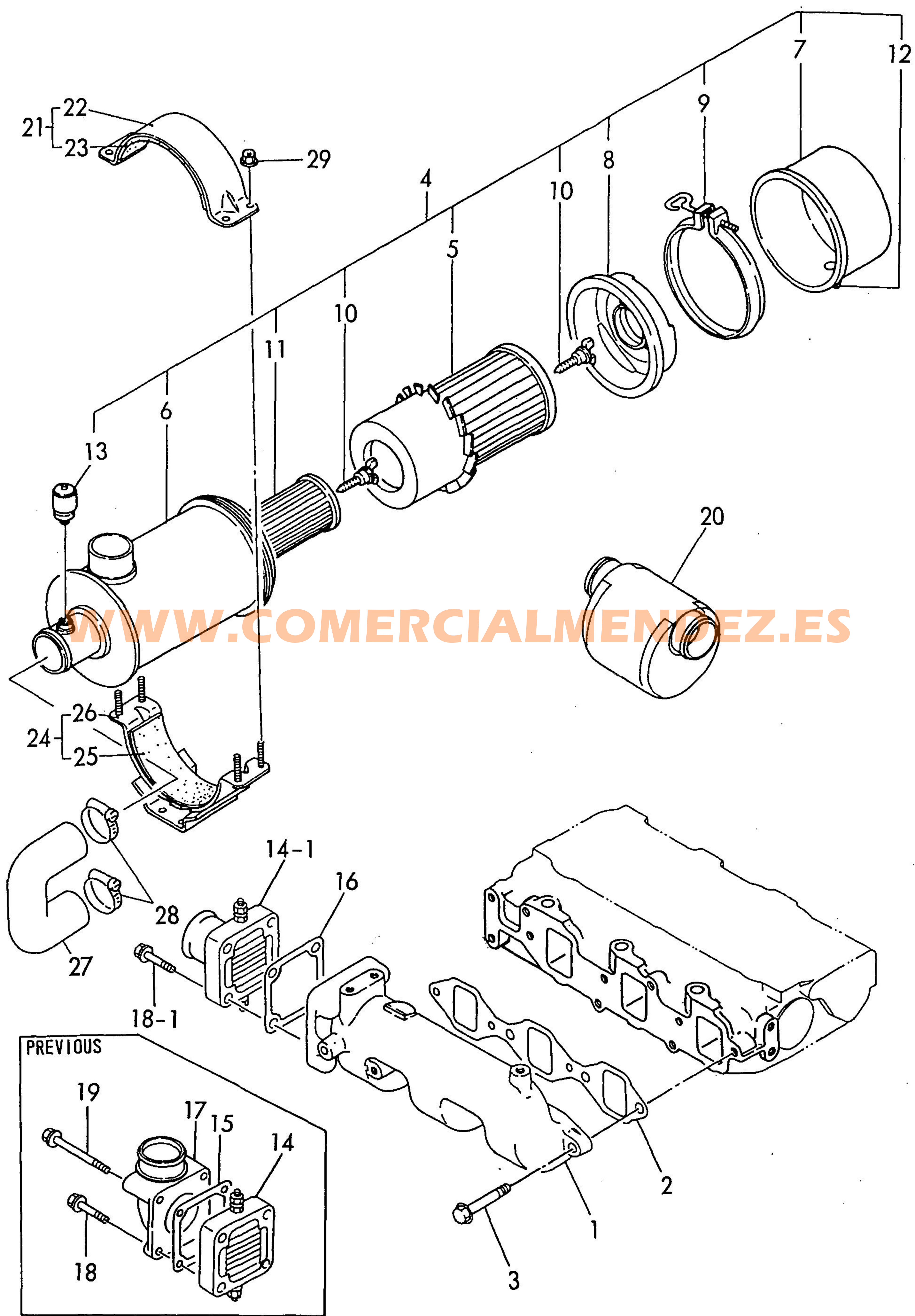

Fig. 5 SUC. MANIFOLD & AIR CLEANER



WWW.COMERCIALMENDEZ.ES

Fig. 6 EXH. MANIFOLD & SILENCER

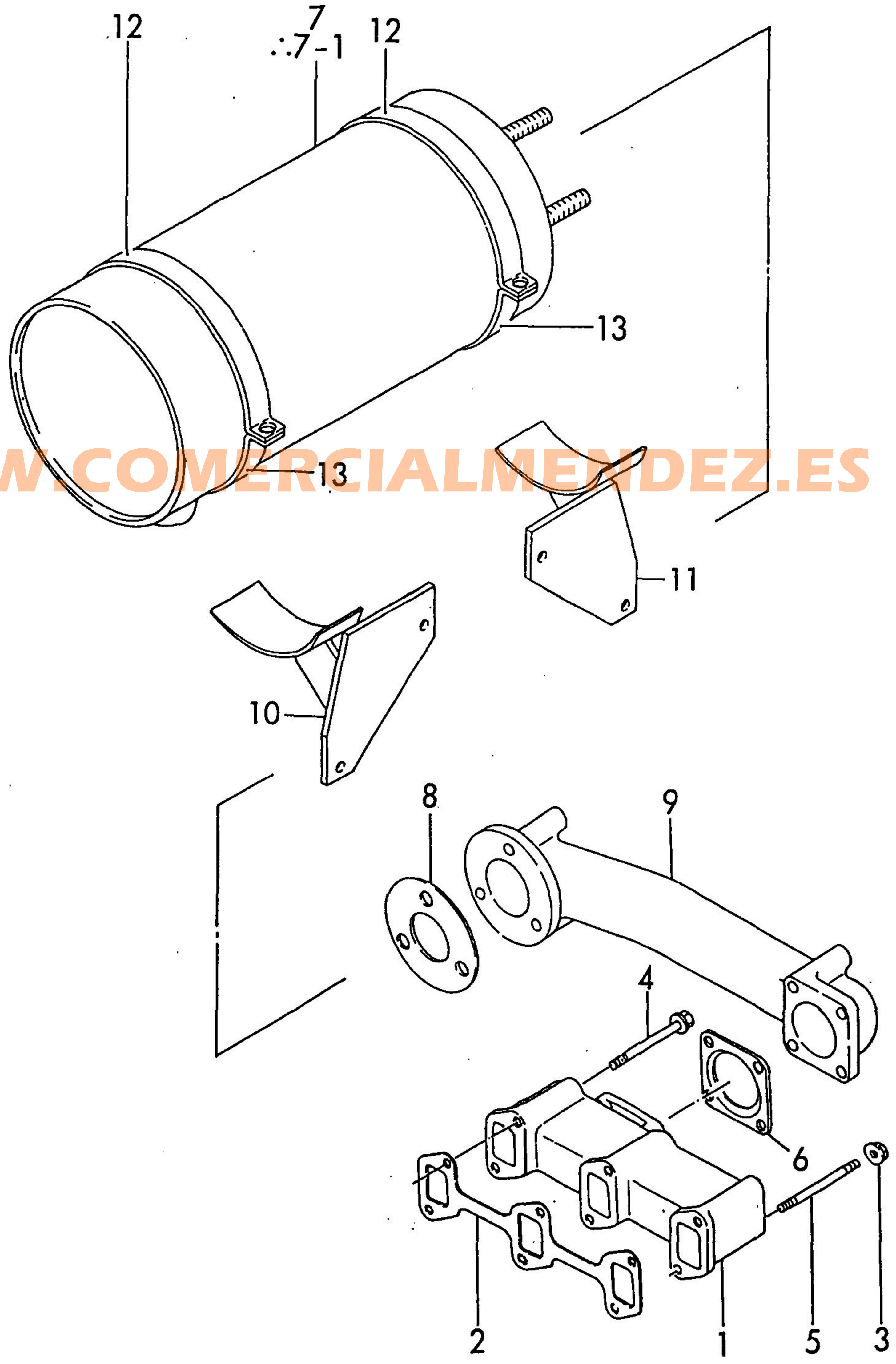
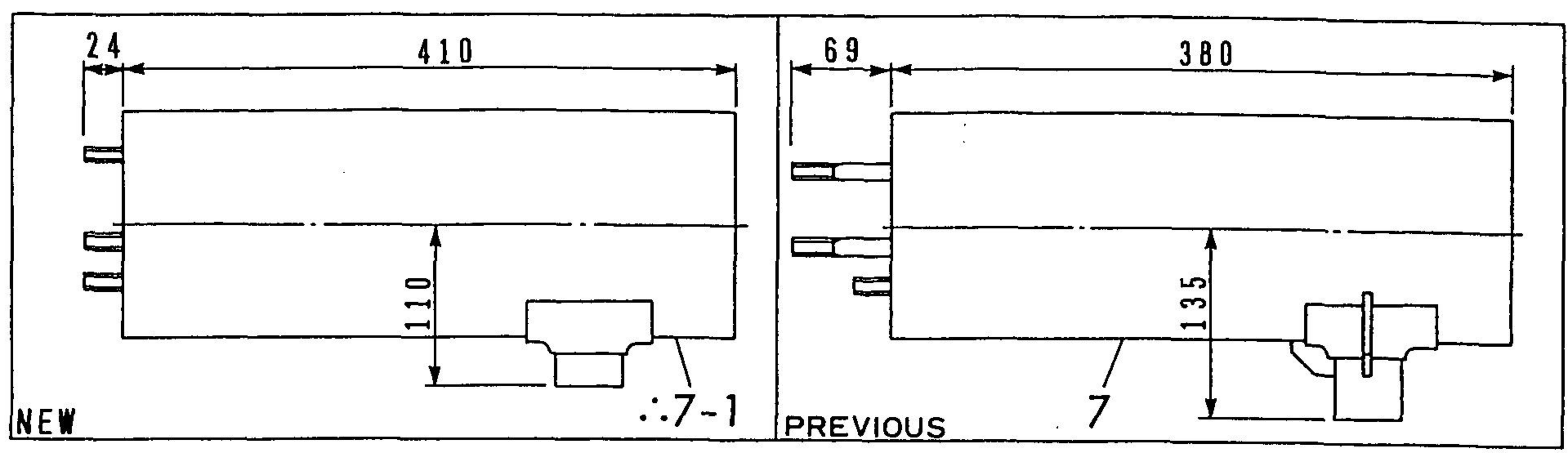

Fig. **7** CAMSHAFT & DRIVING GEAR

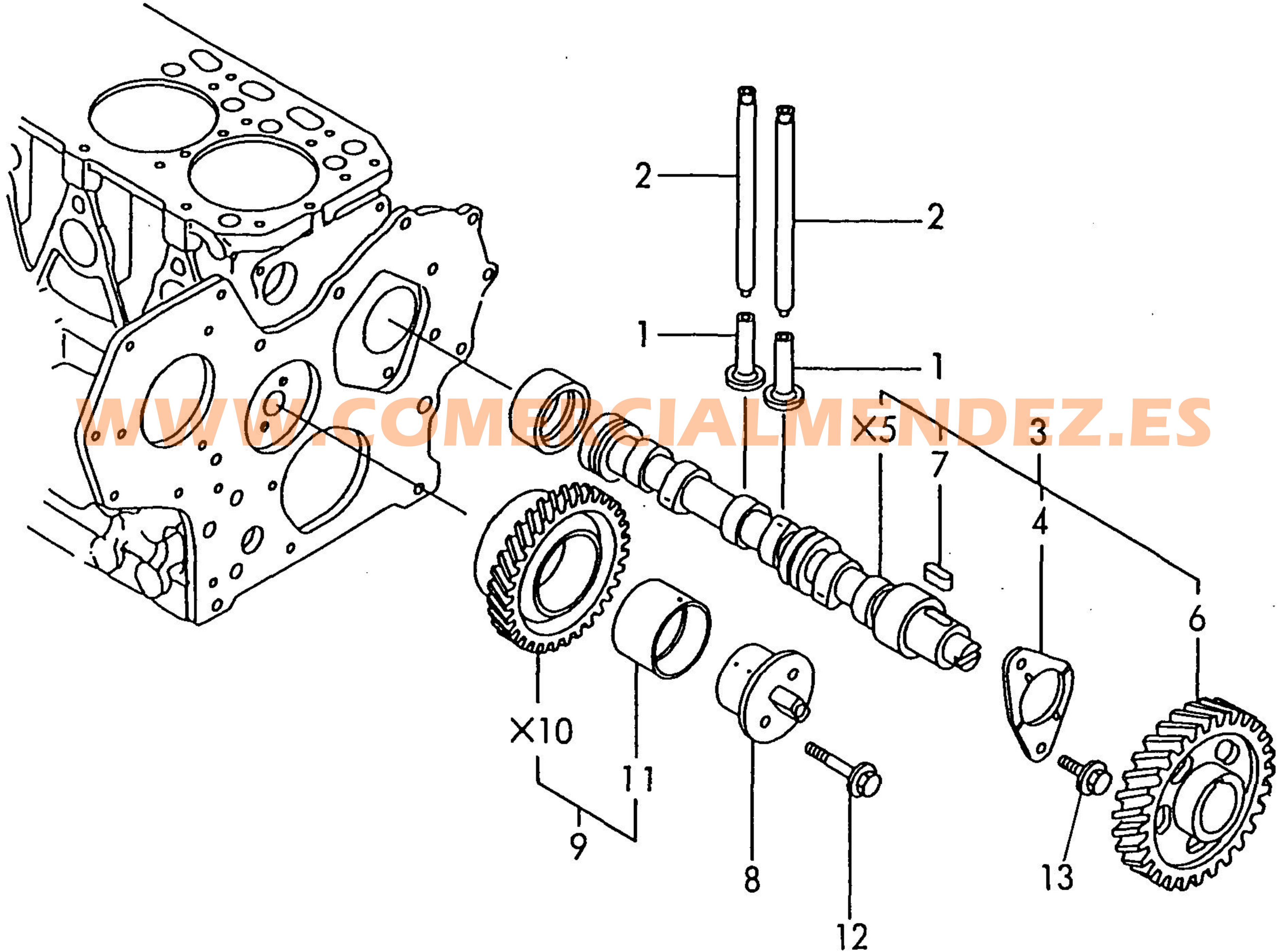

Fig. 8 CRANKSHAFT & PISTON

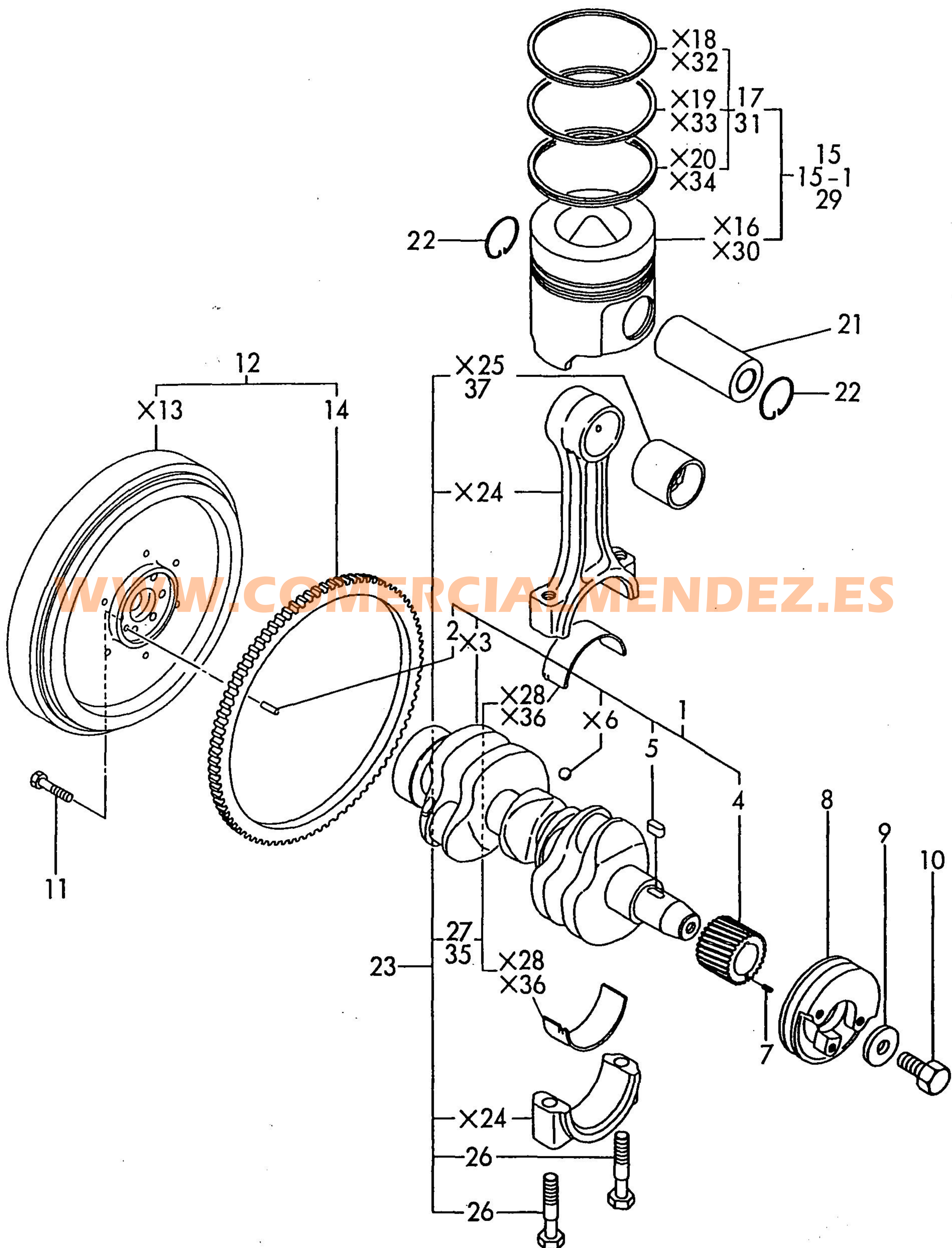
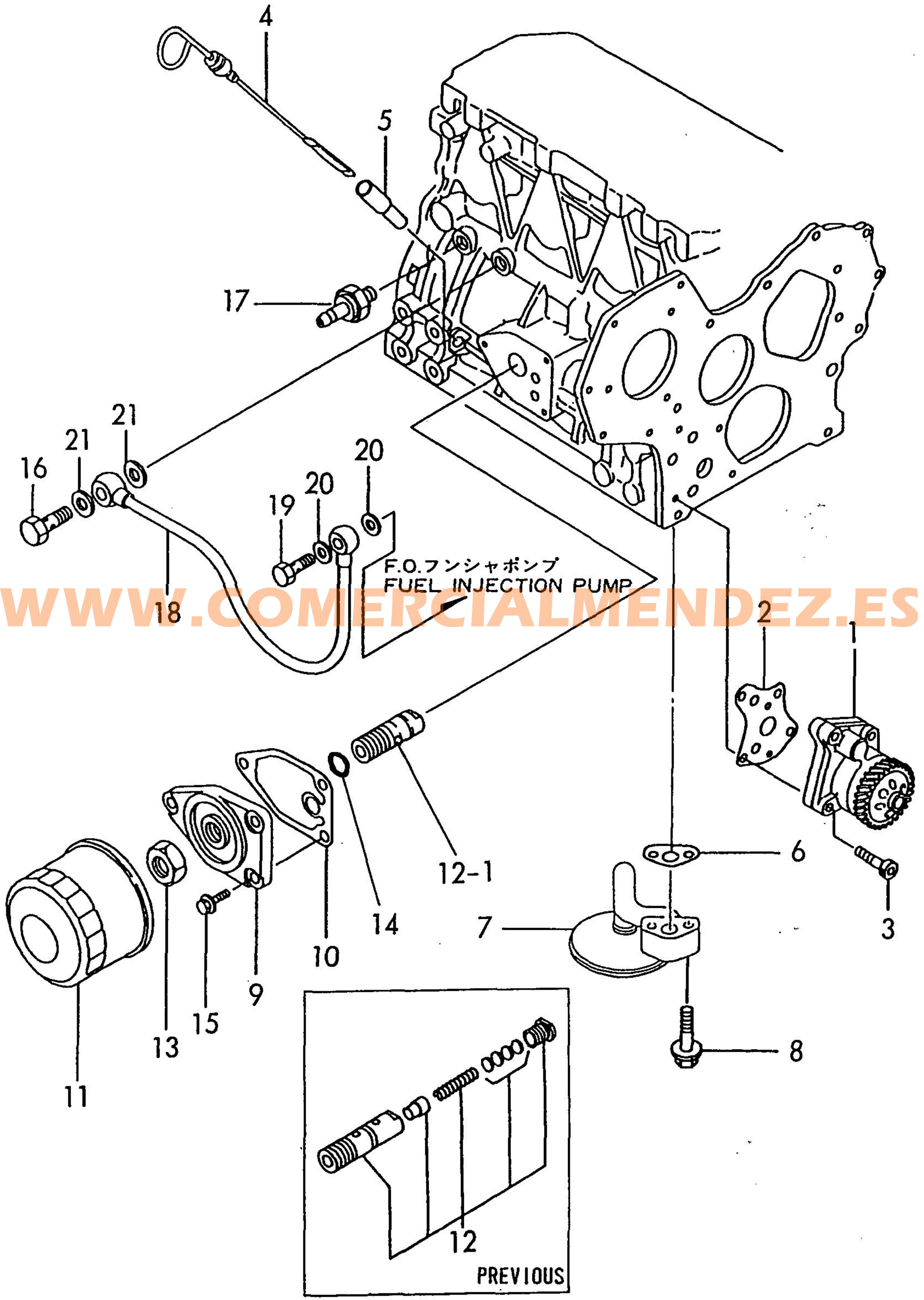

Fig. 9 LUB. OIL SYSTEM



WWW.COMERCIALMENDEZ.ES

Fig. 10 COOLING WATER SYSTEM

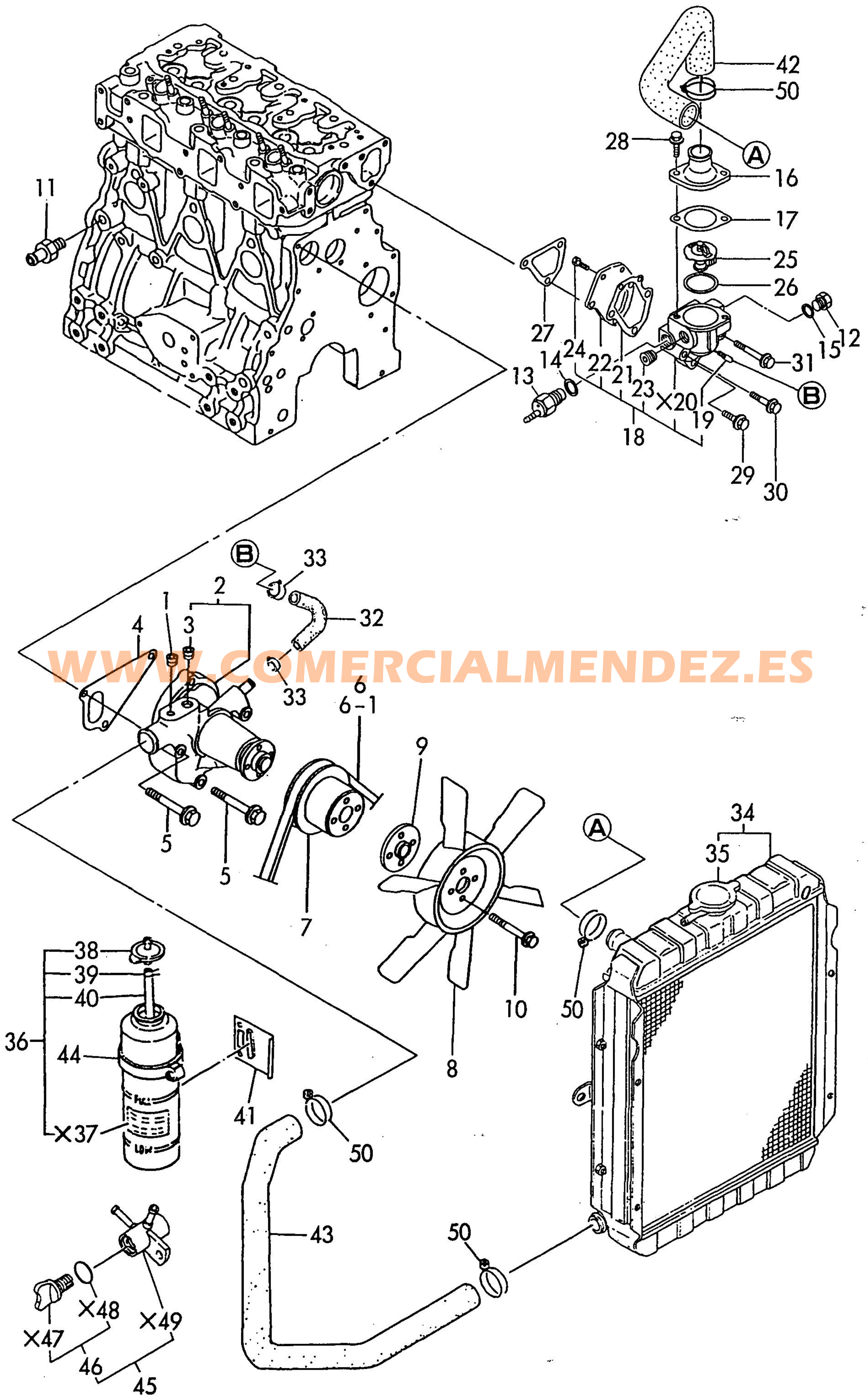

Fig. 11 FUEL INJECTION PUMP

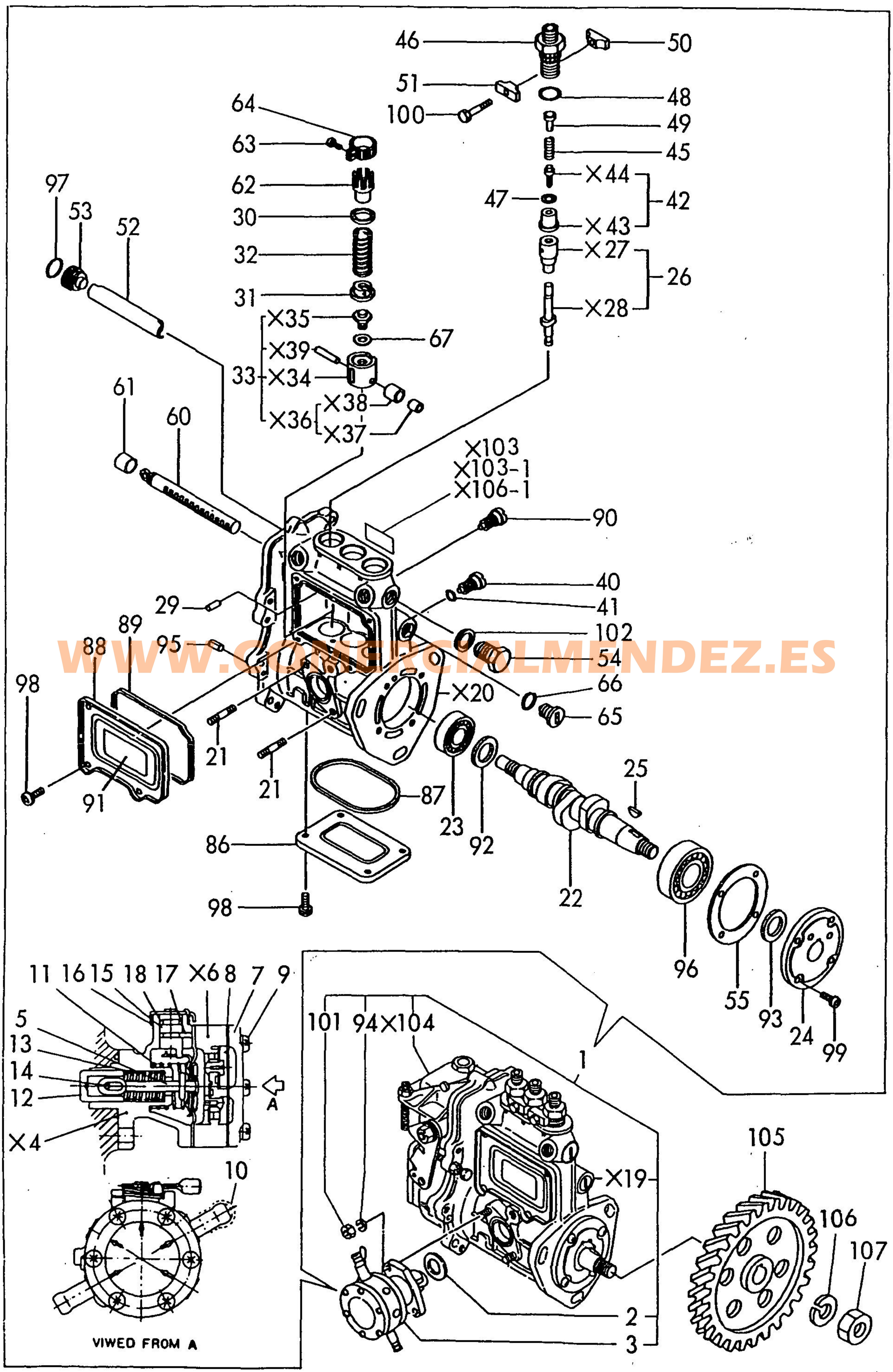
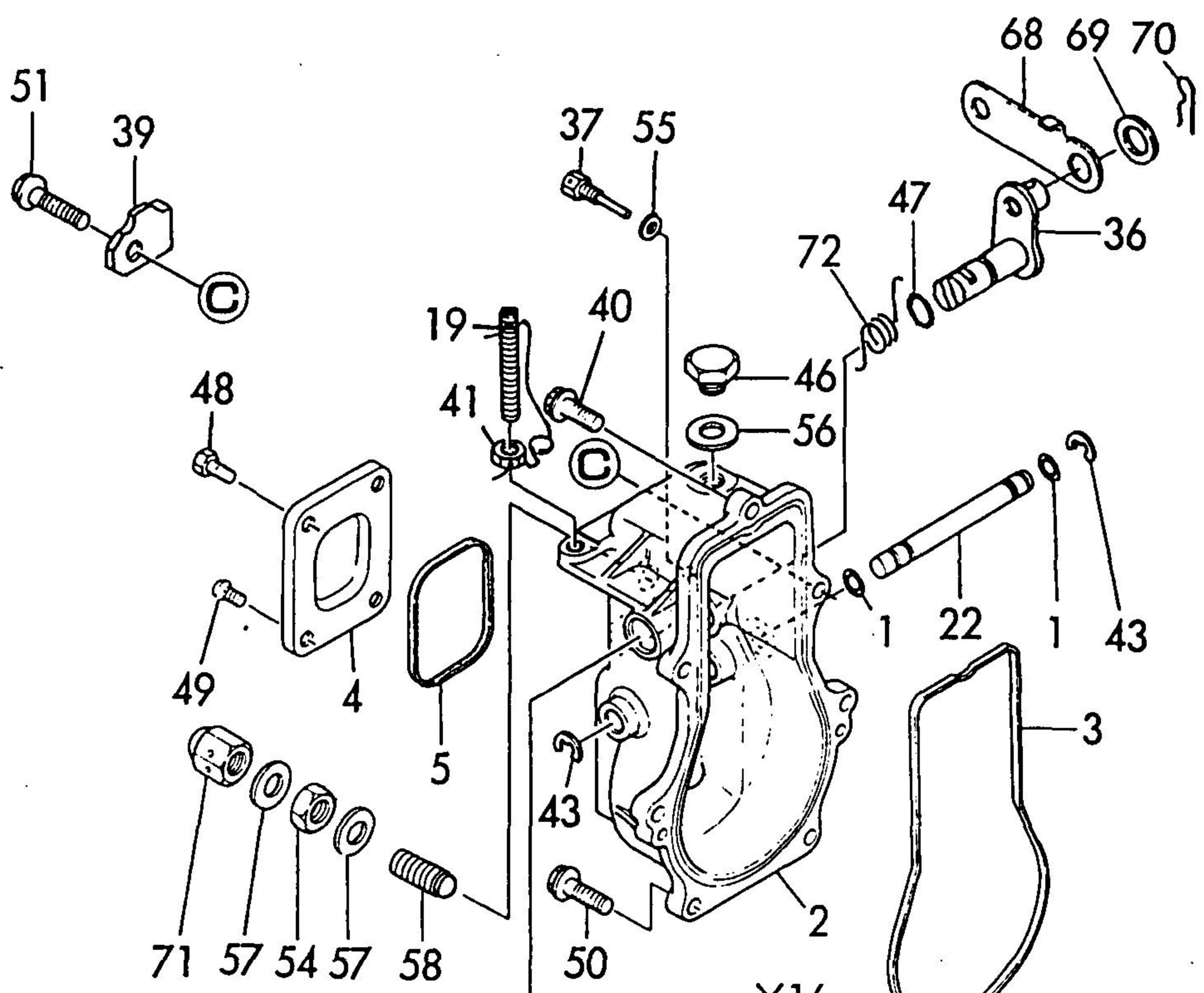

Fig. 12 GOVERNOR



WWW.COMERCIALMENDEZ.ES

シキベツ マーク
CLASSIFIED MARK

REFER TO FIG. 11

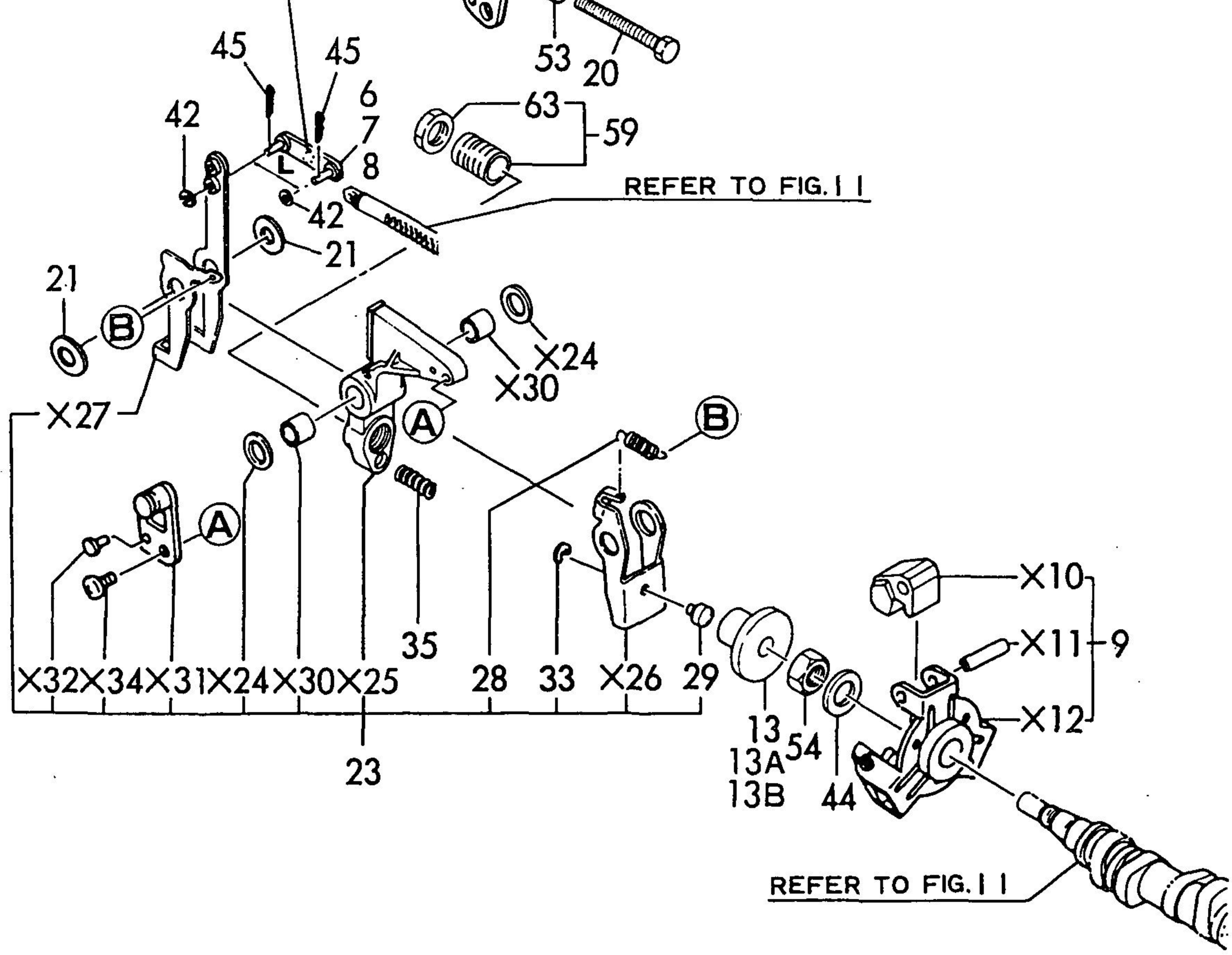

REFER TO FIG. 11

Fig. 13 FUEL INJECTION VALVE

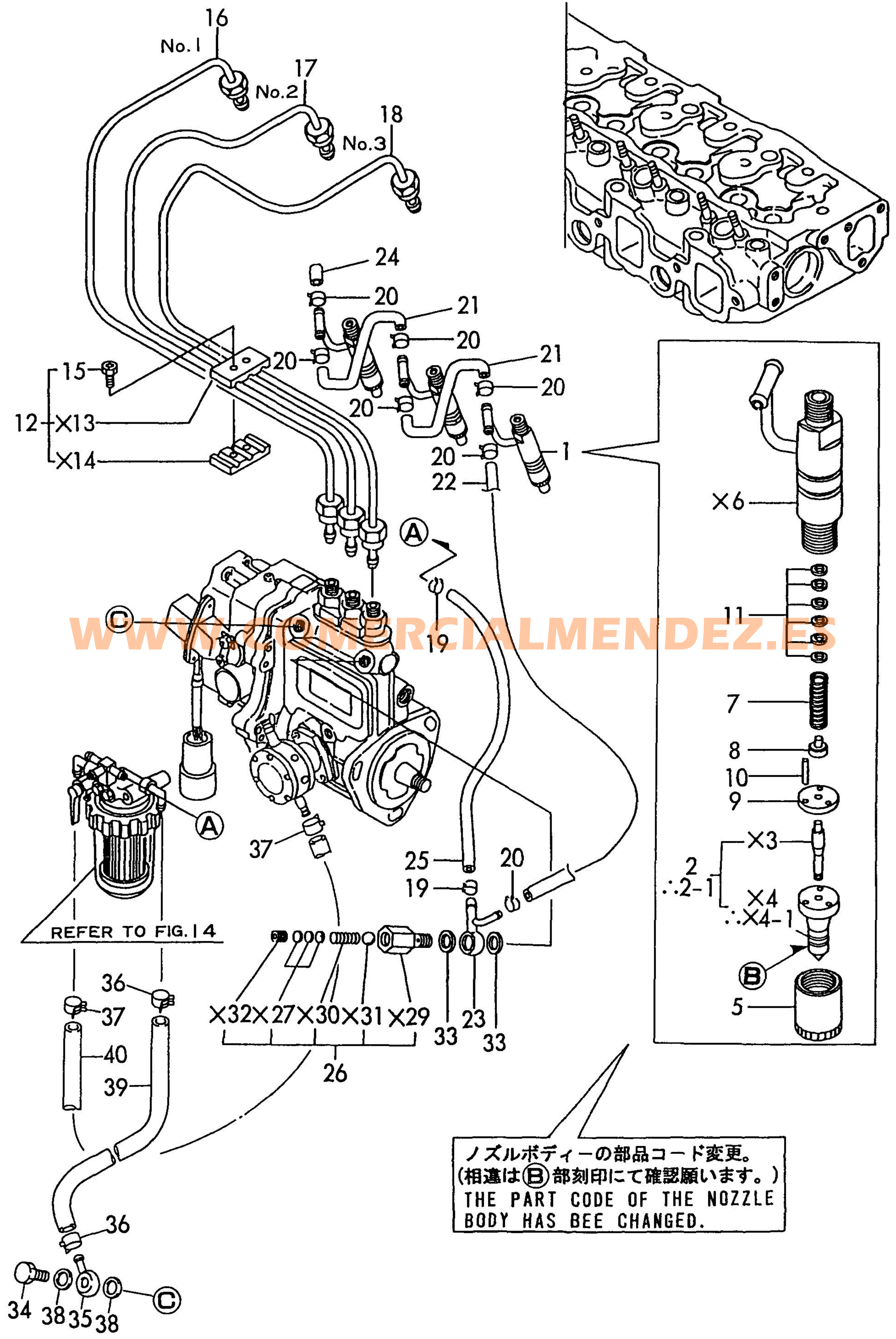
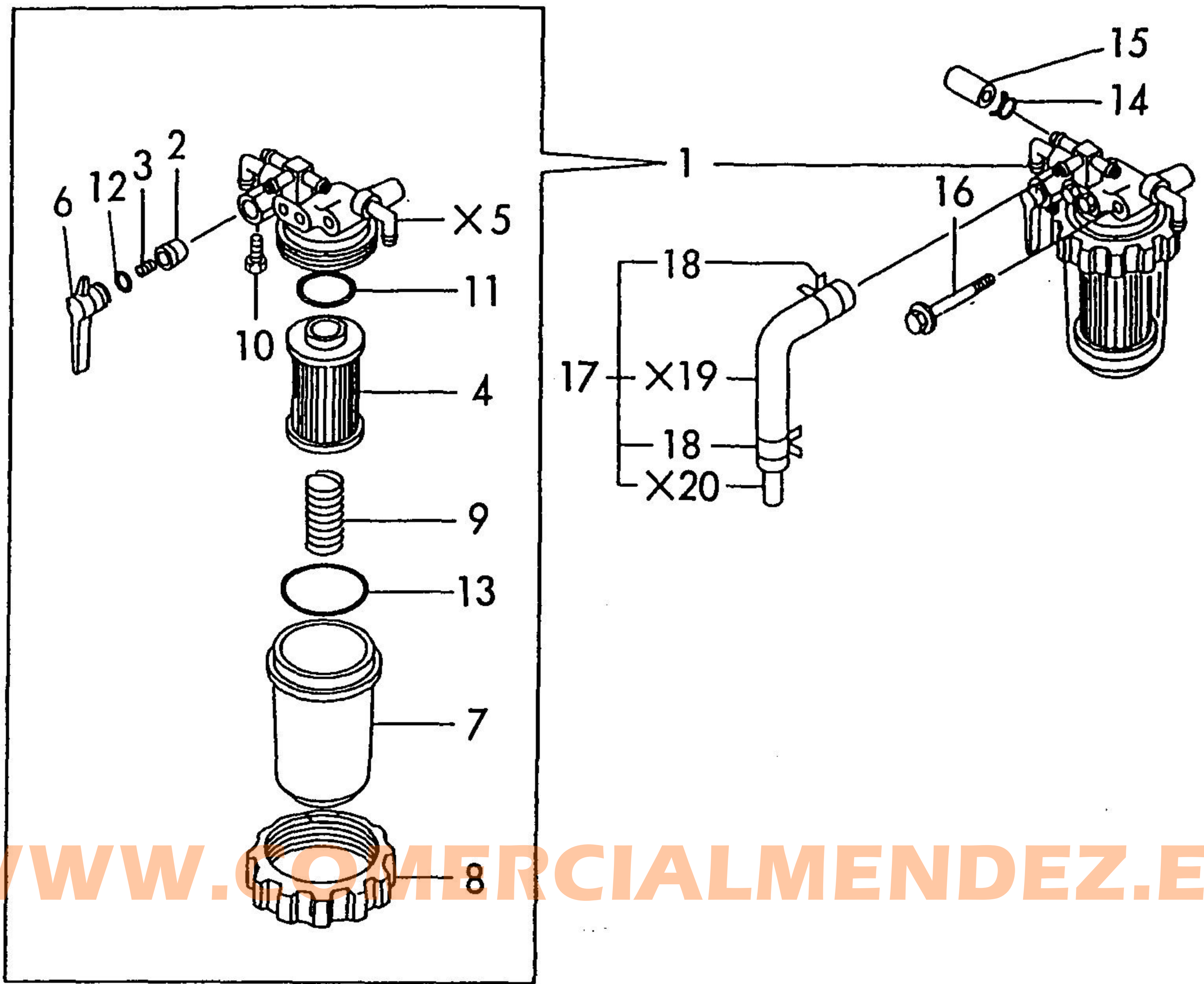

Fig. **14** FUEL STRAINER & OIL/WATER SEPARATOR



WWW.COMERCIALMENDEZ.ES

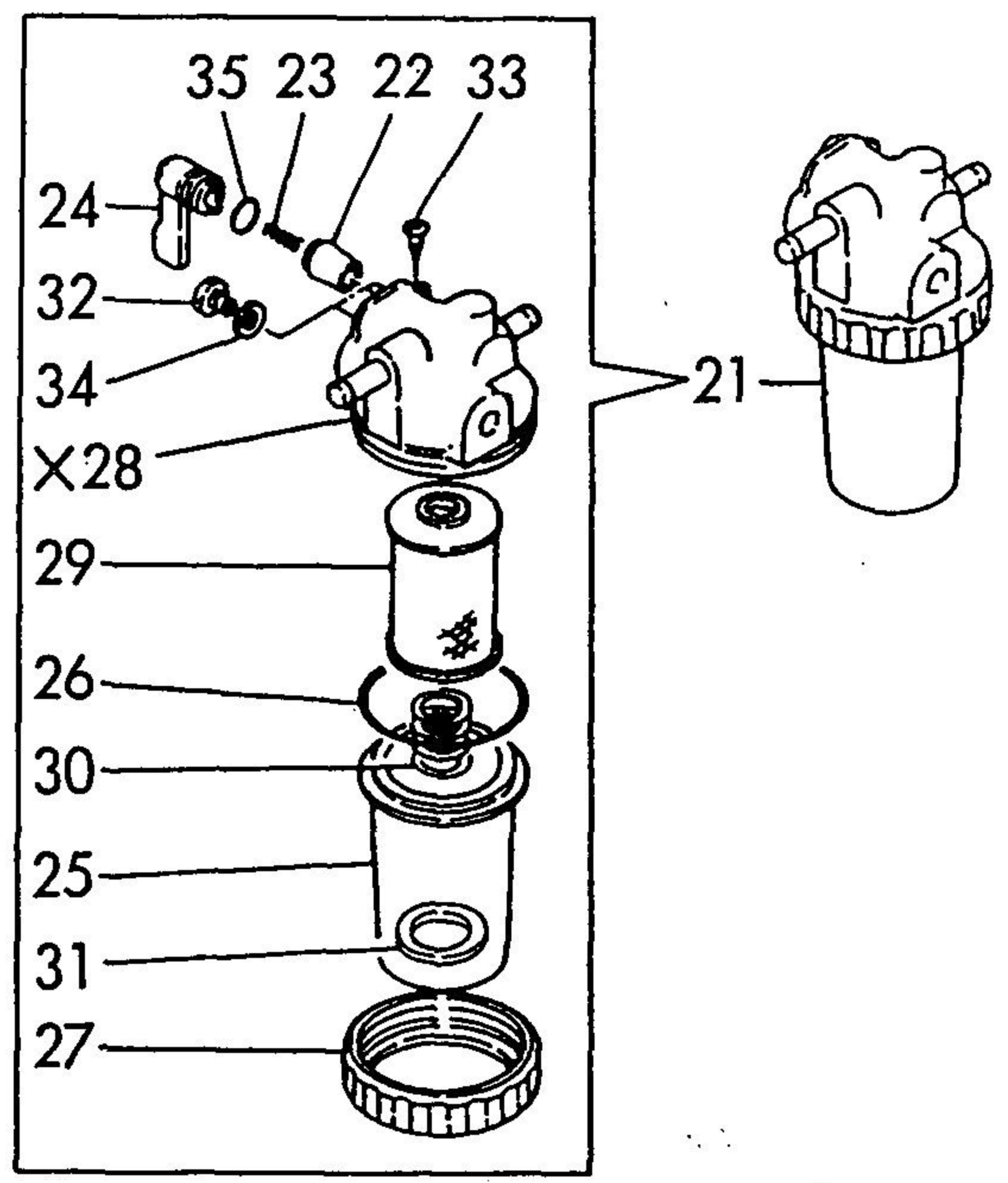

Fig. 1 CYLINDER BLOCK

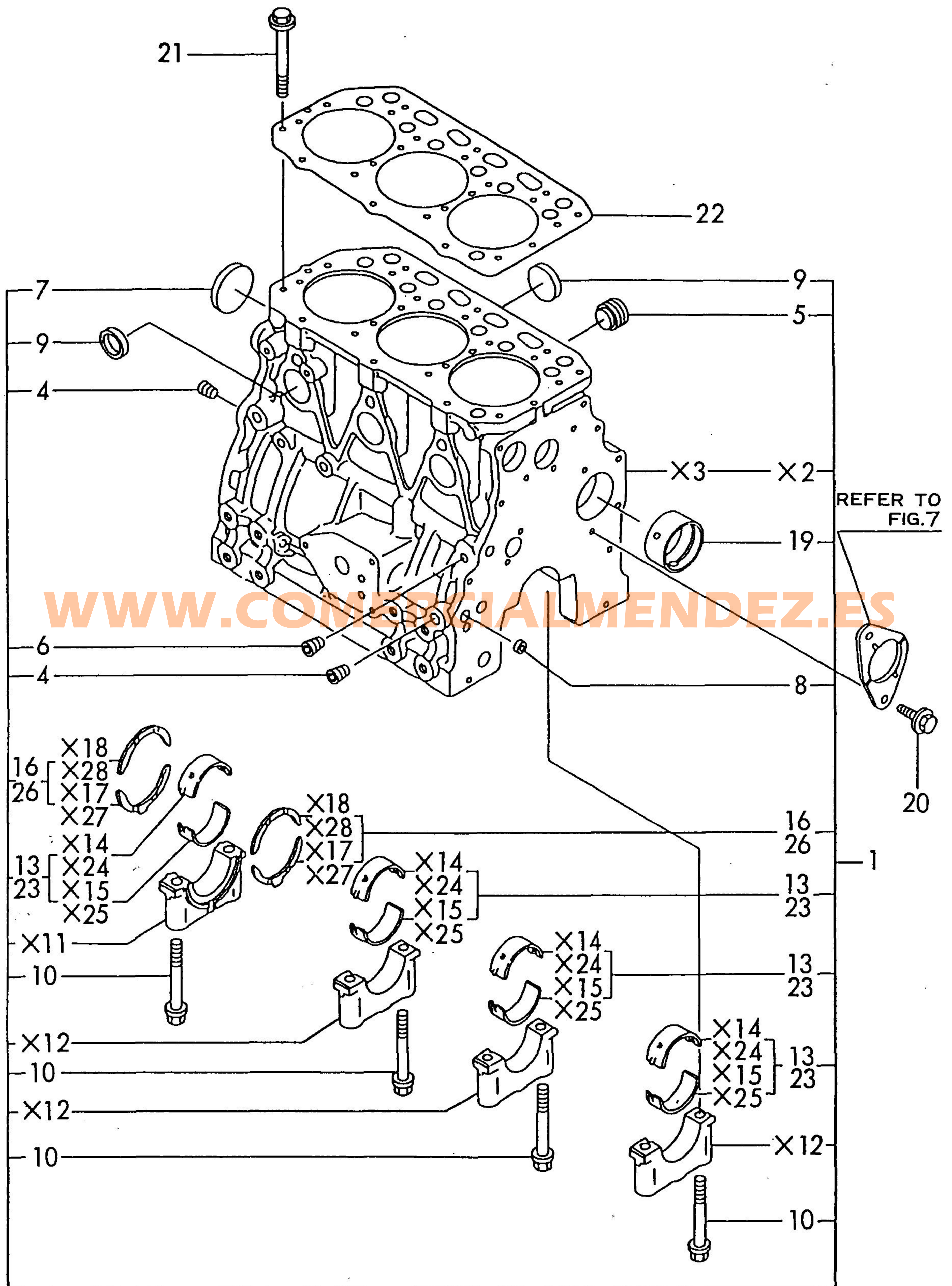
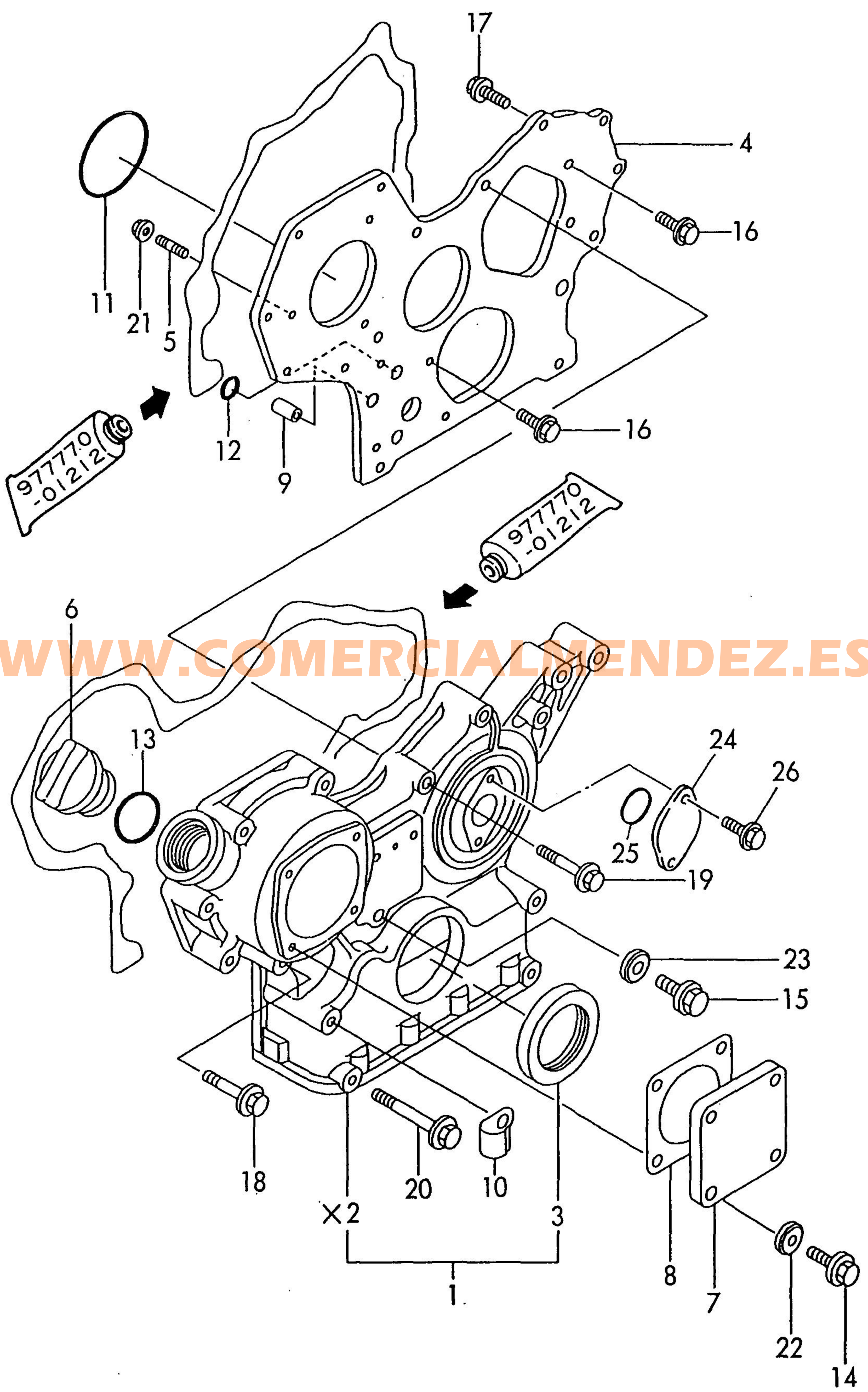

Fig. 2 GEAR HOUSING



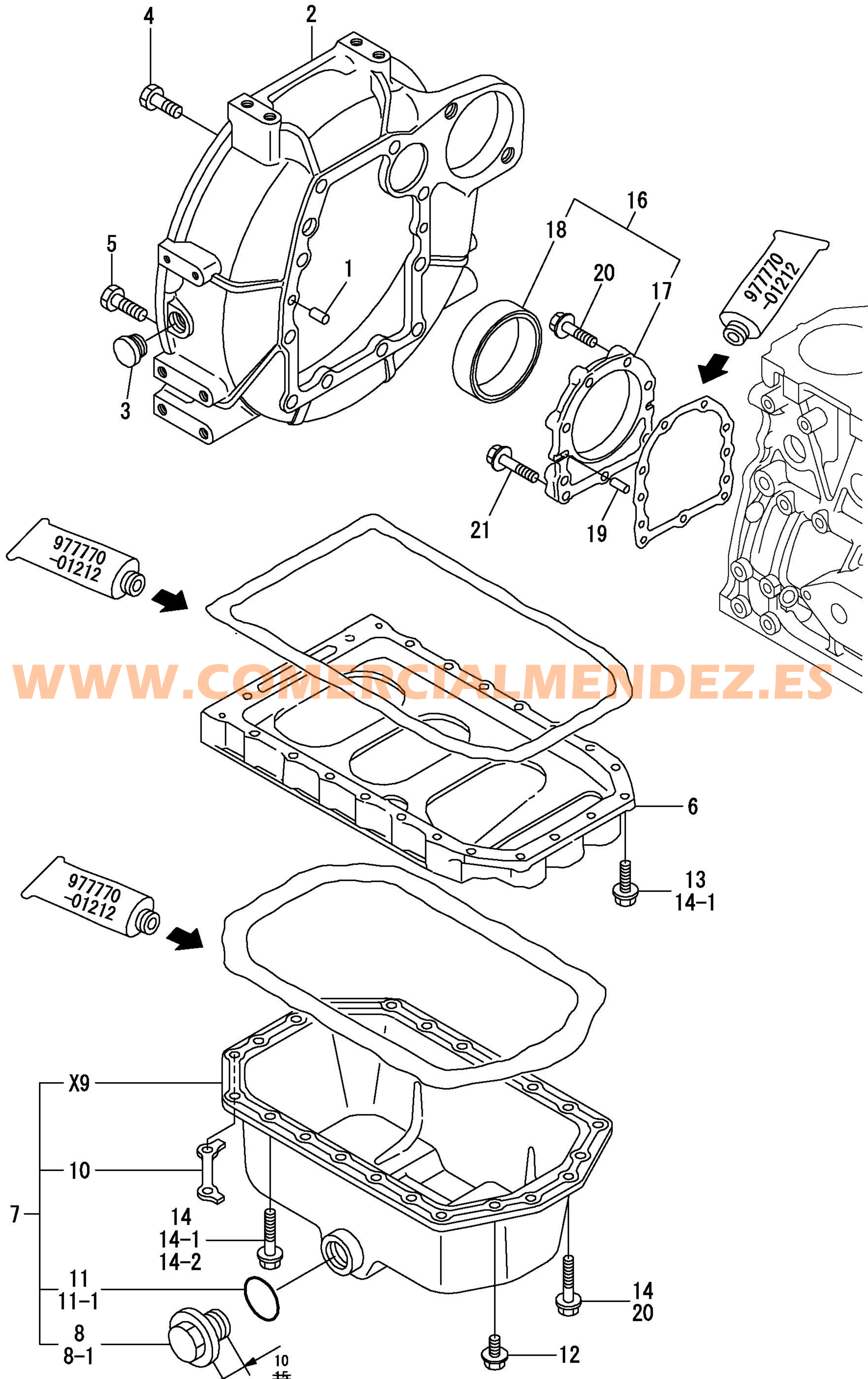

Fig. 4 CYLINDER HEAD & BONNET

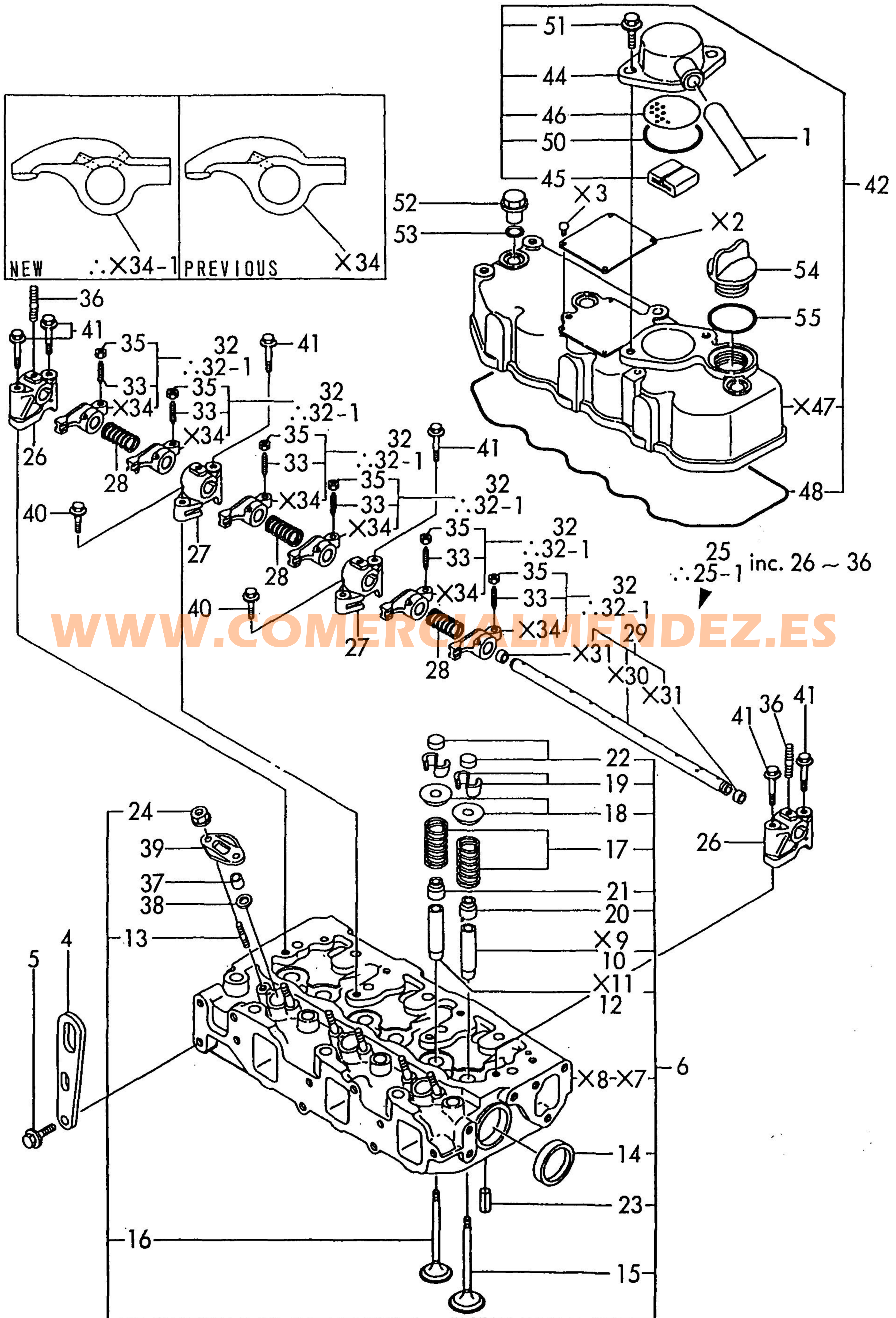

Fig. 5 SUC. MANIFOLD & AIR CLEANER

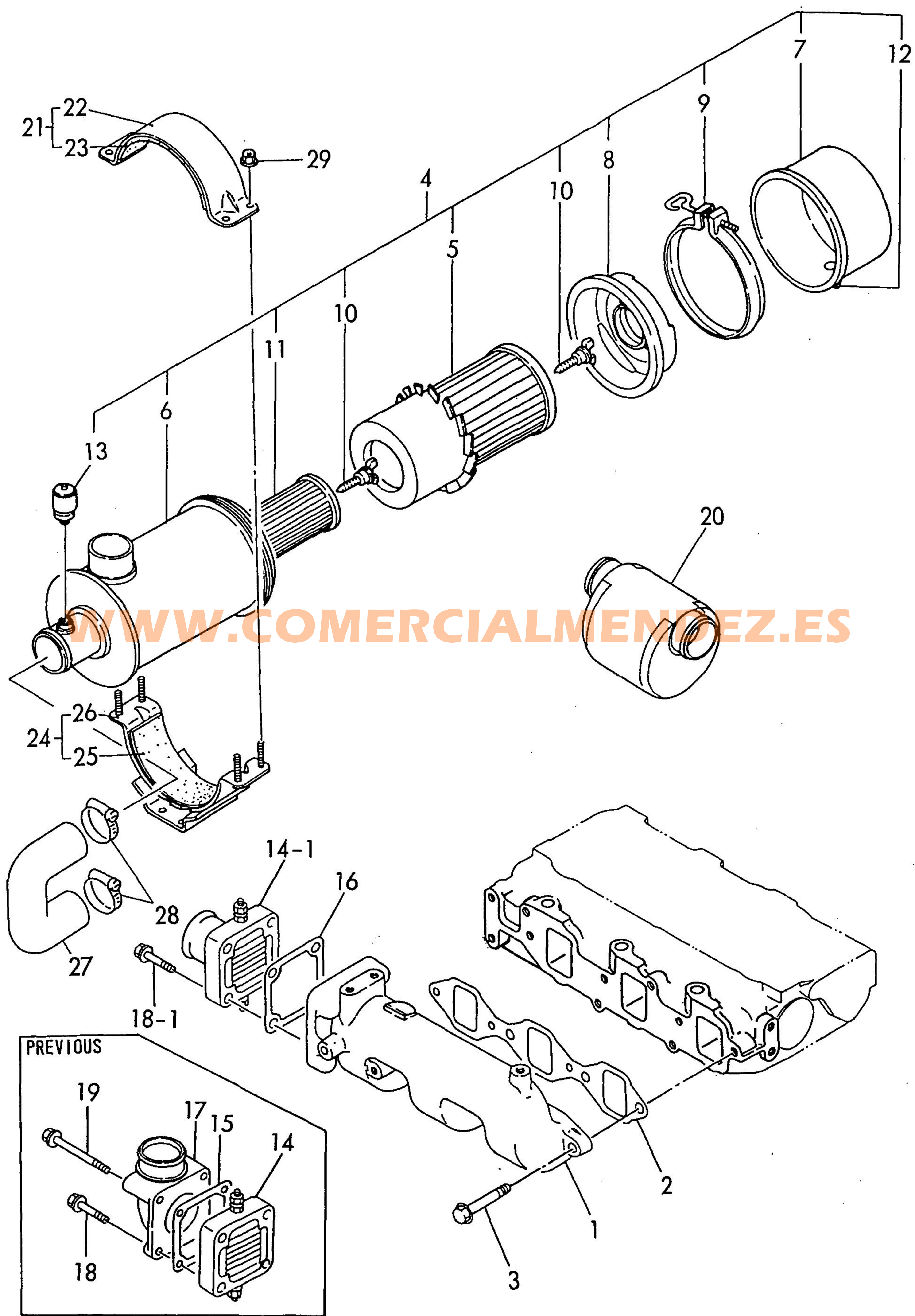

Fig. 6 EXH. MANIFOLD & SILENCER

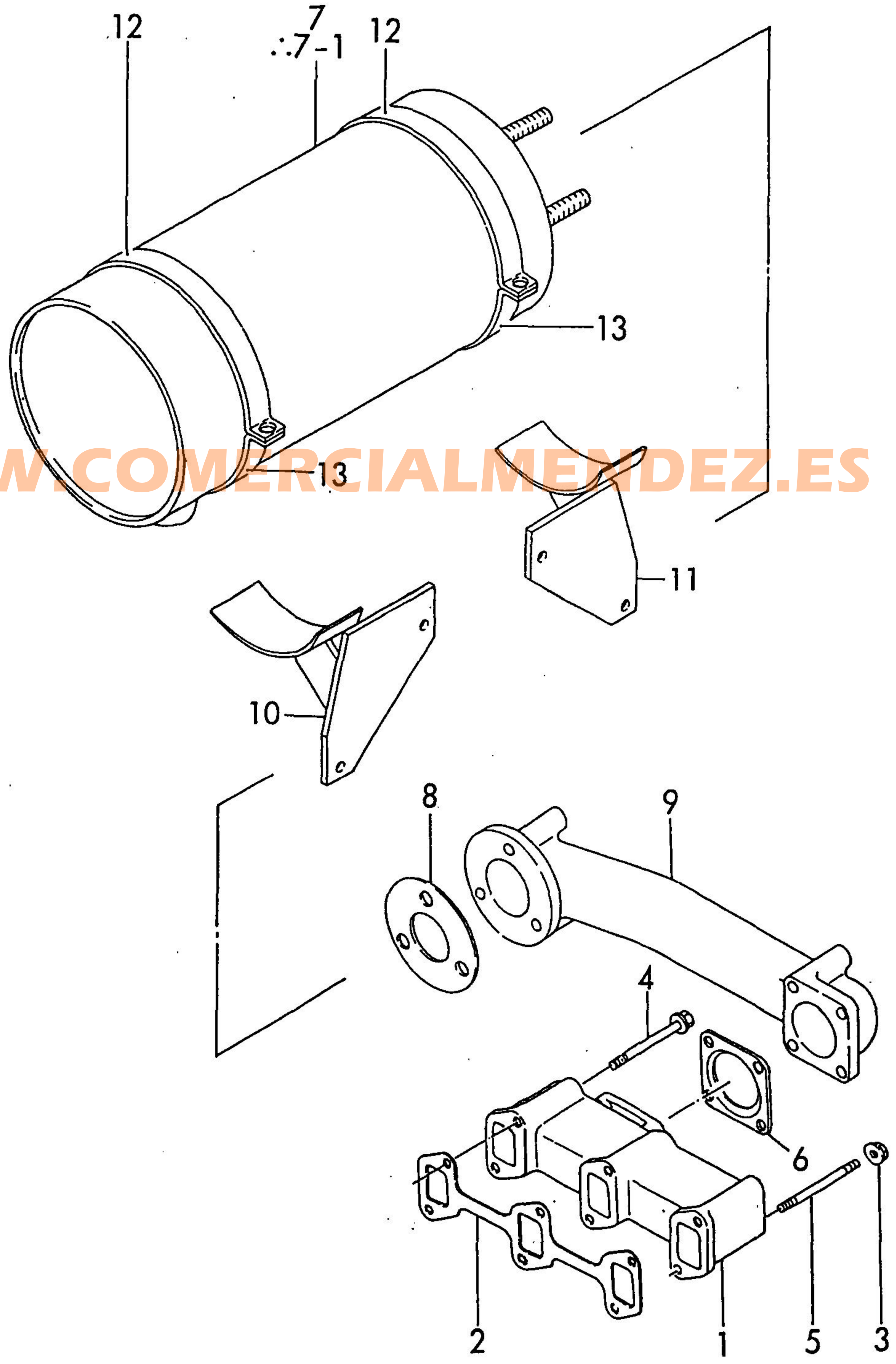
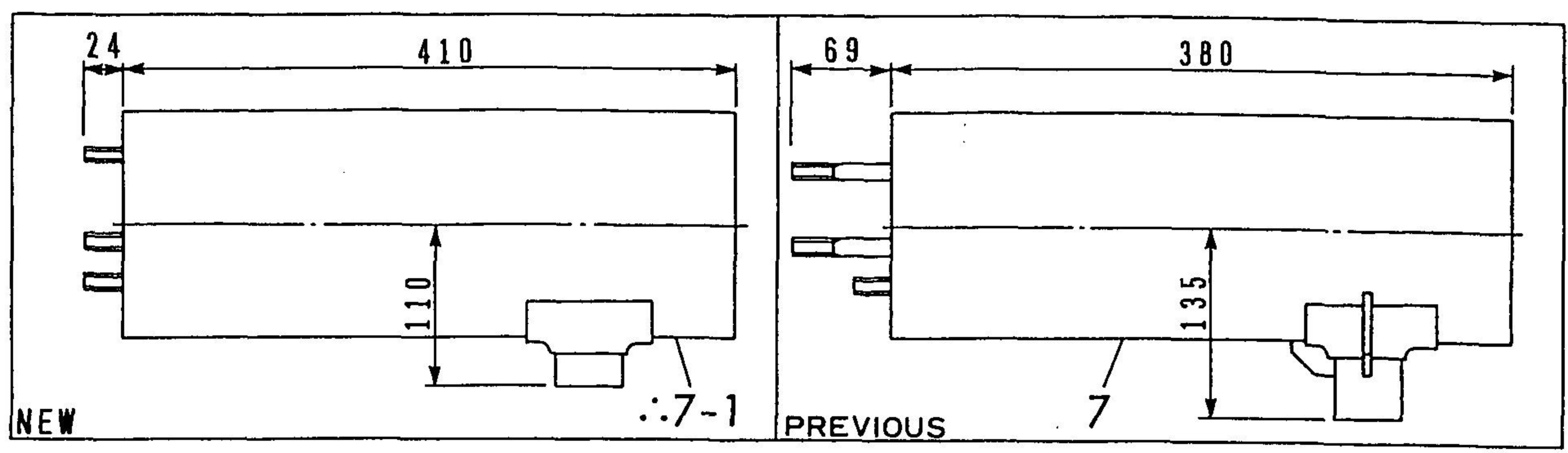

Fig. **7** CAMSHAFT & DRIVING GEAR

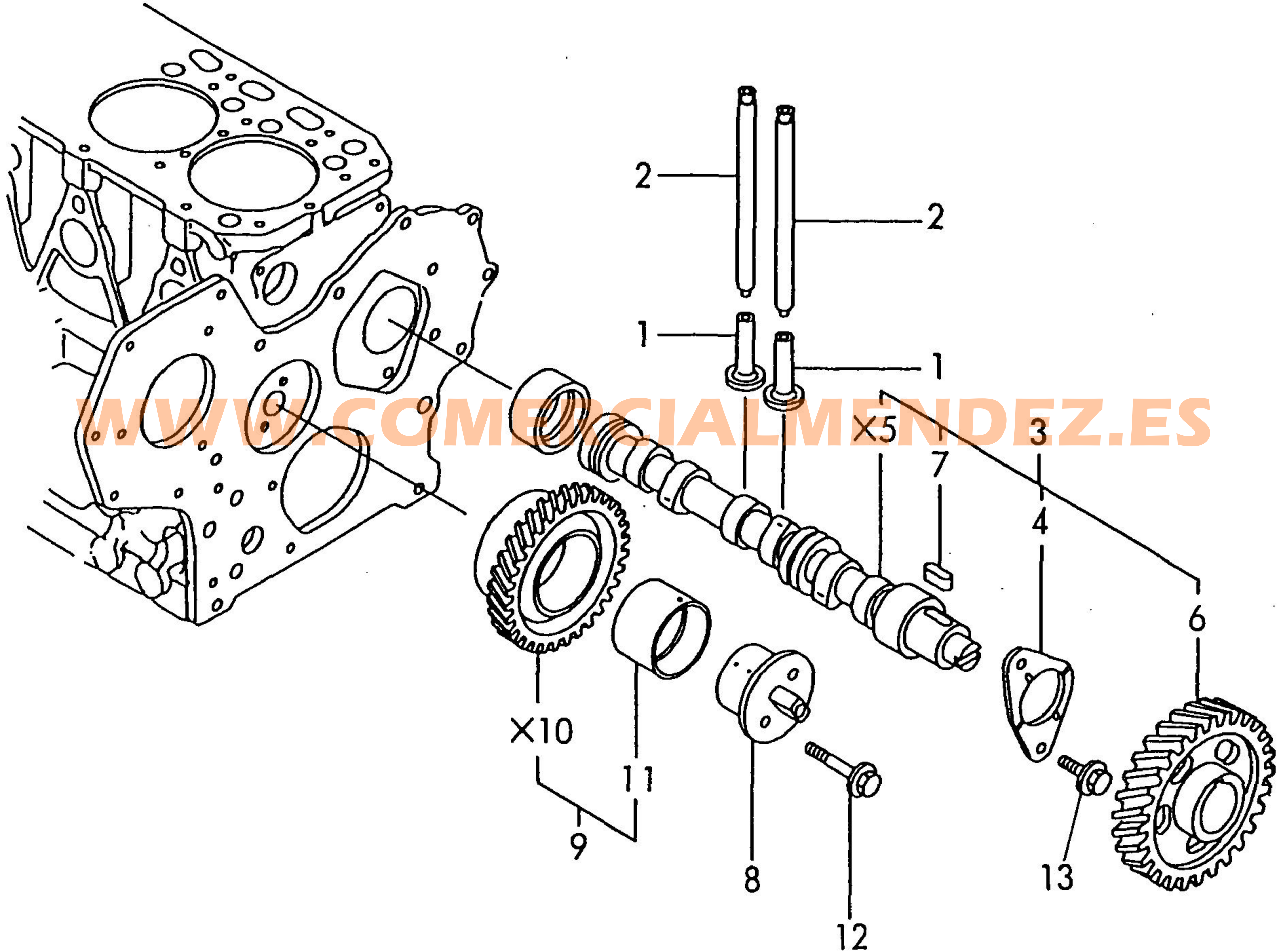

Fig. 8 CRANKSHAFT & PISTON

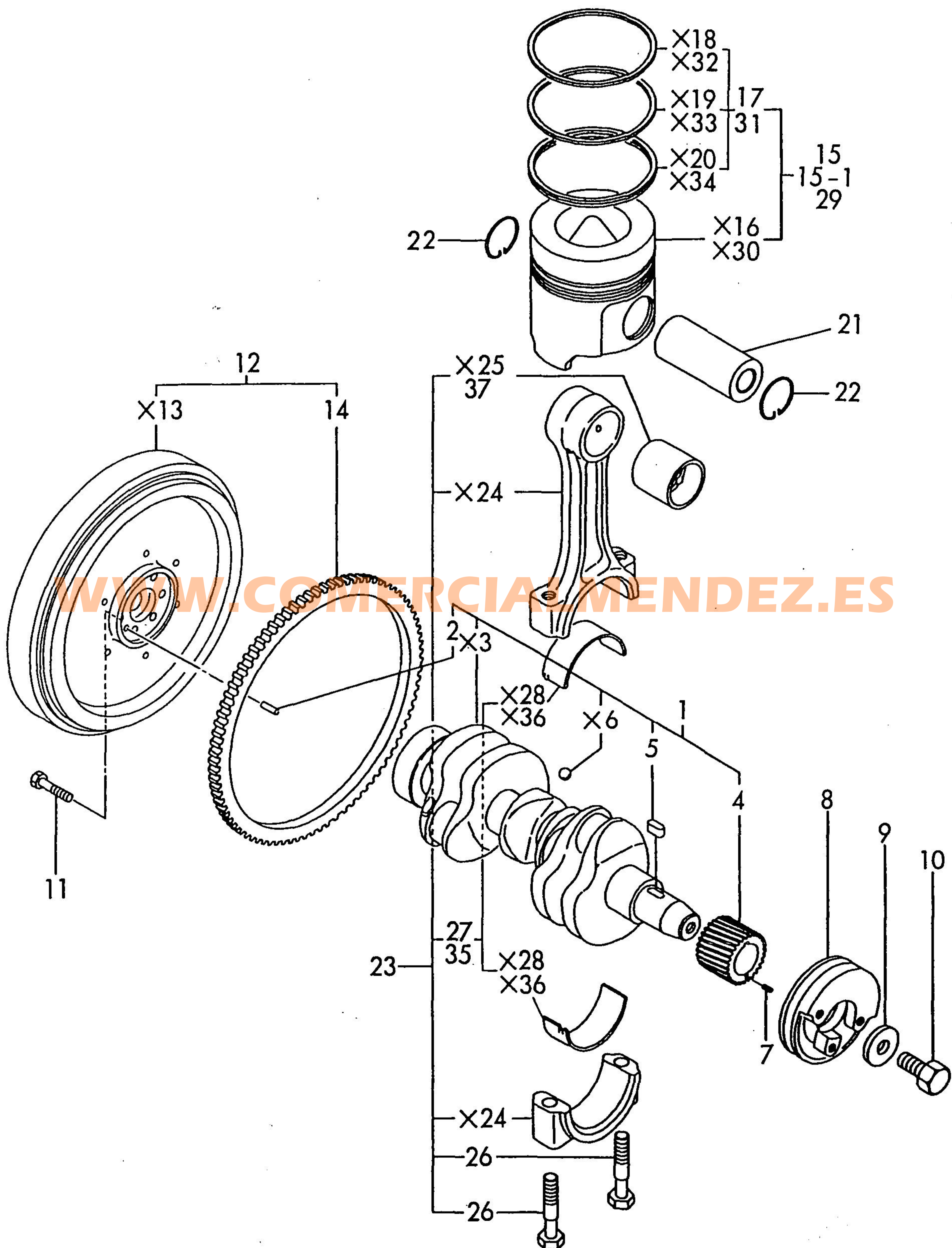
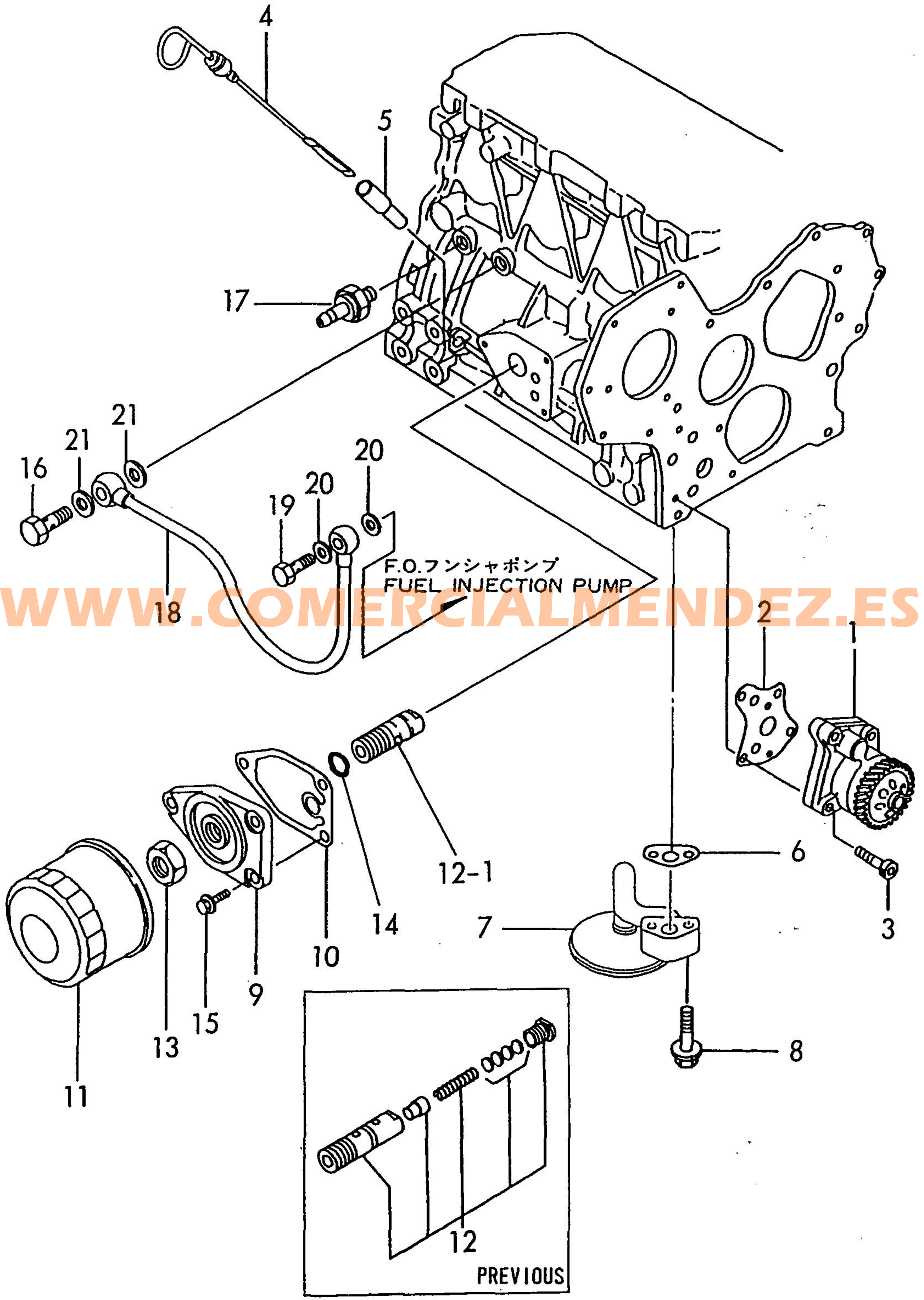

Fig. 9 LUB. OIL SYSTEM



WWW.COMERCIALMENDEZ.ES

Fig. 10 COOLING WATER SYSTEM

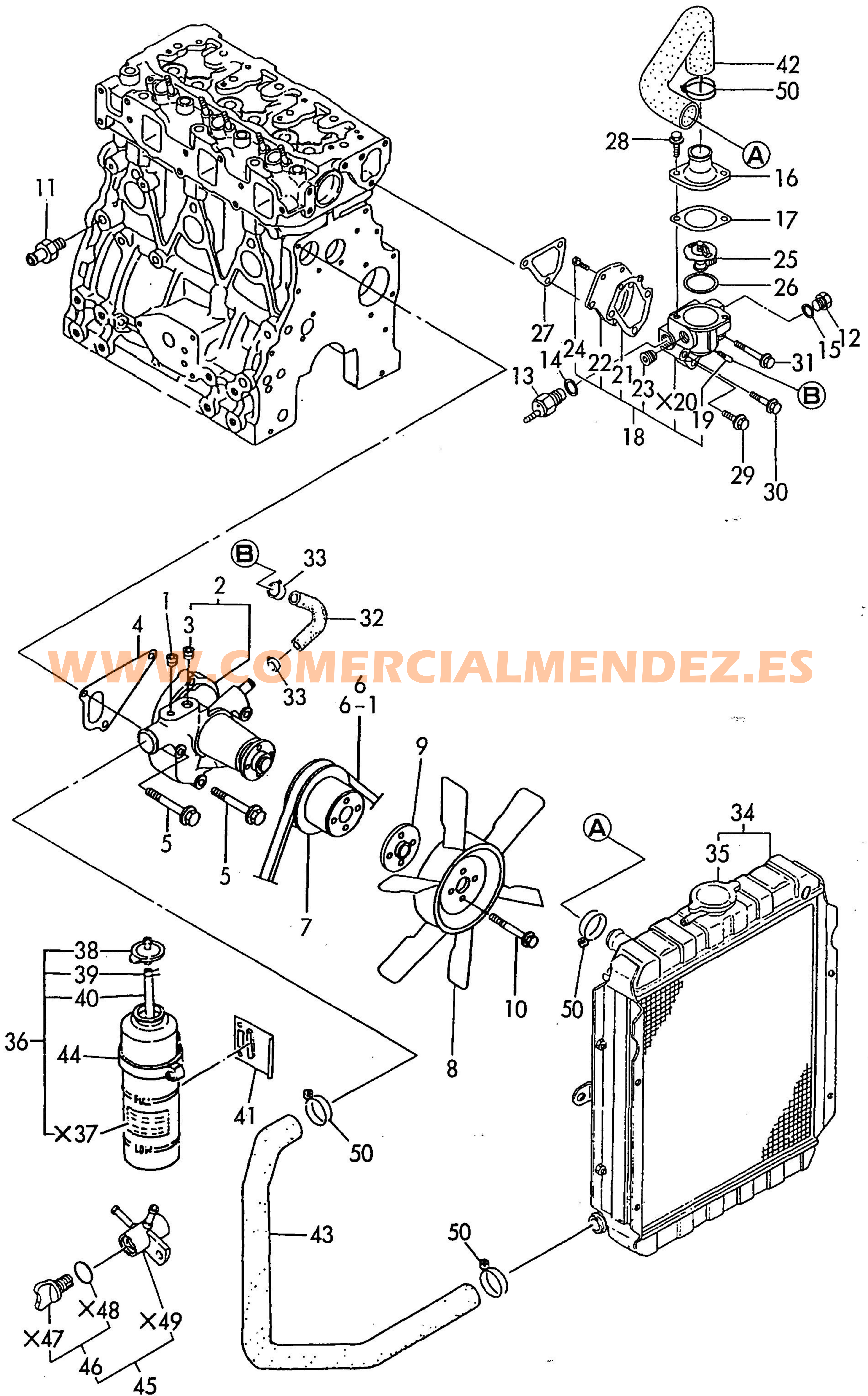

Fig. 11 FUEL INJECTION PUMP

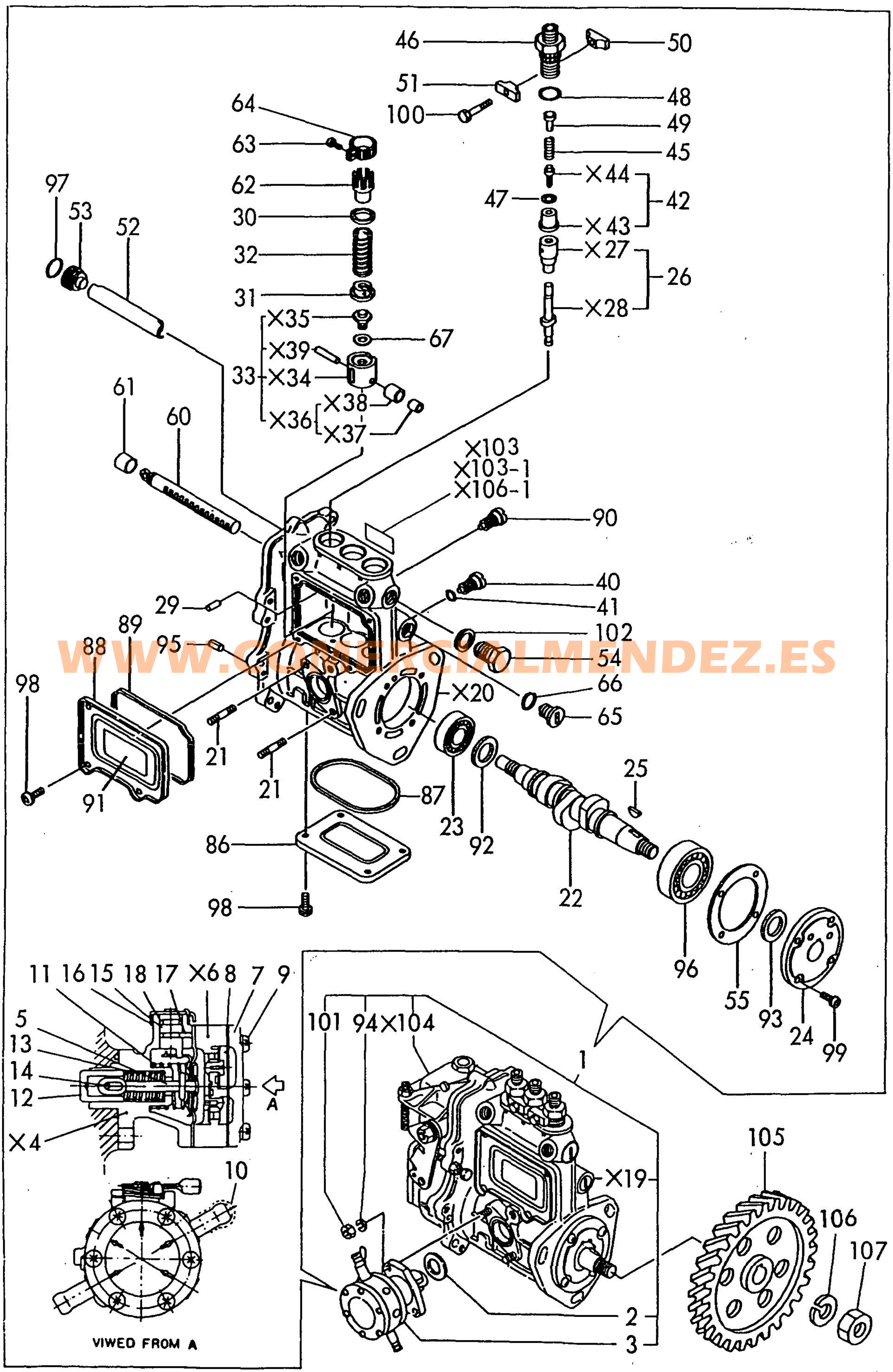
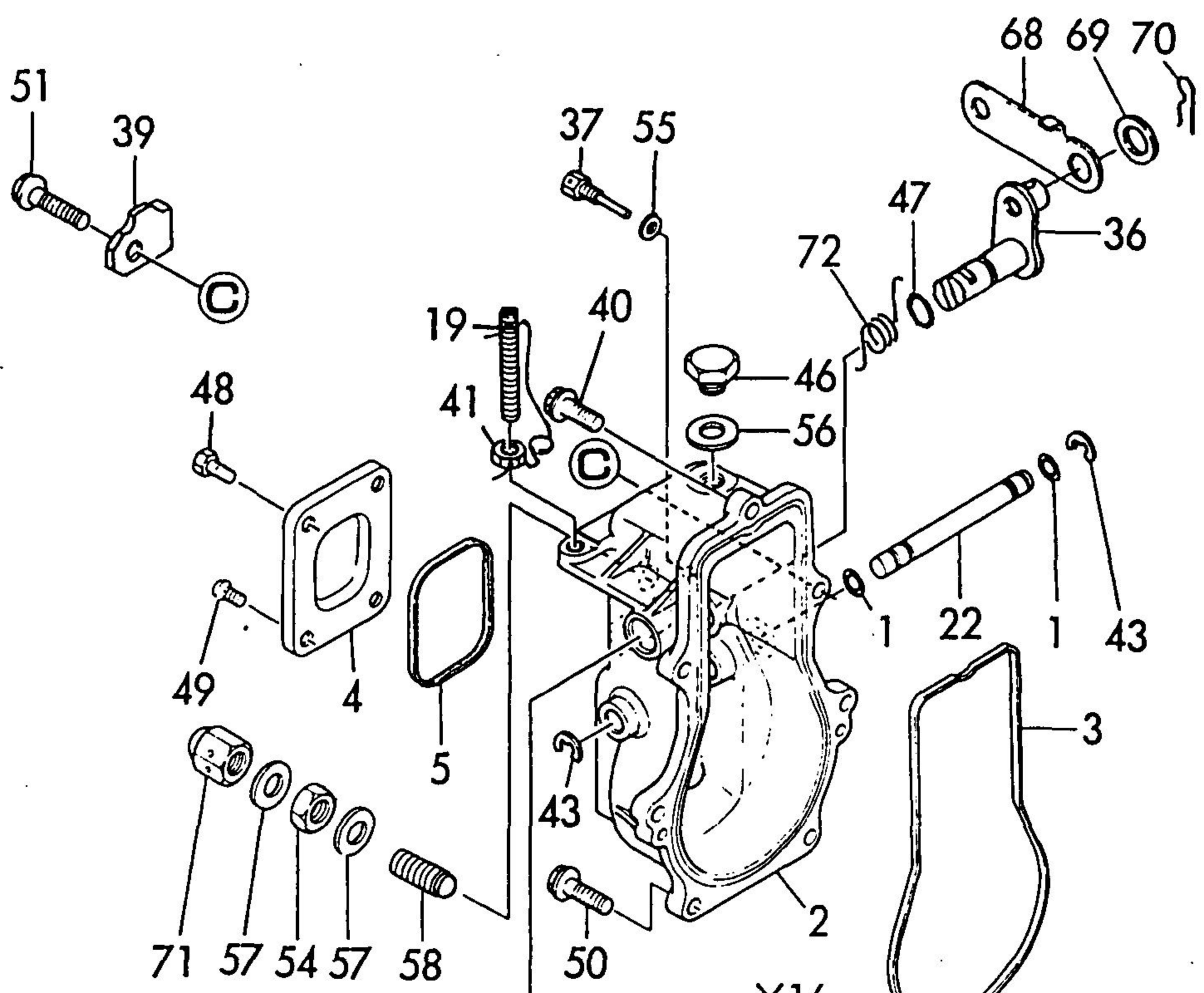

Fig. 12 GOVERNOR



WWW.COMERCIALMENDEZ.ES

シキベツ マーク
CLASSIFIED MARK

REFER TO FIG. 11

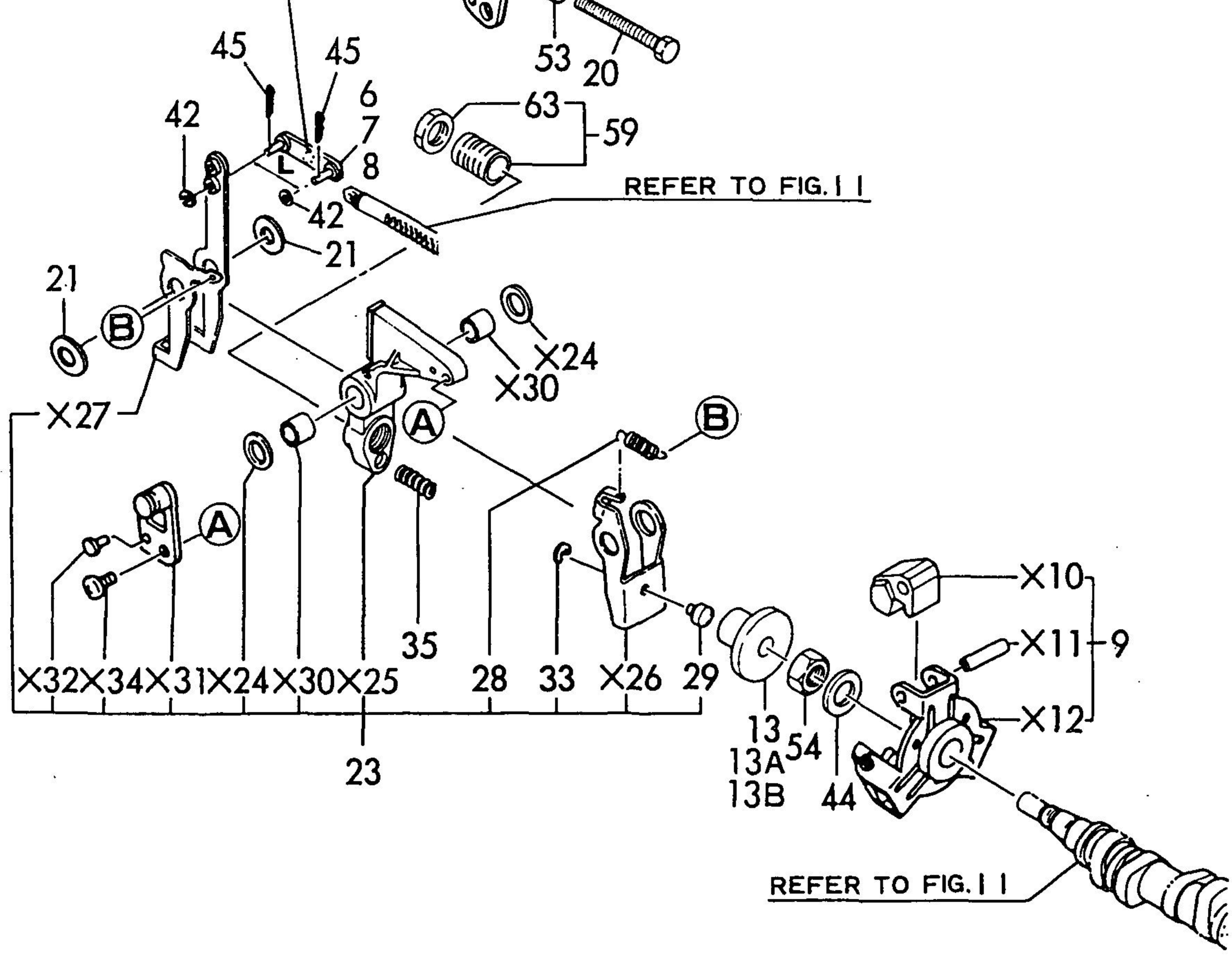

REFER TO FIG. 11

Fig. 13 FUEL INJECTION VALVE

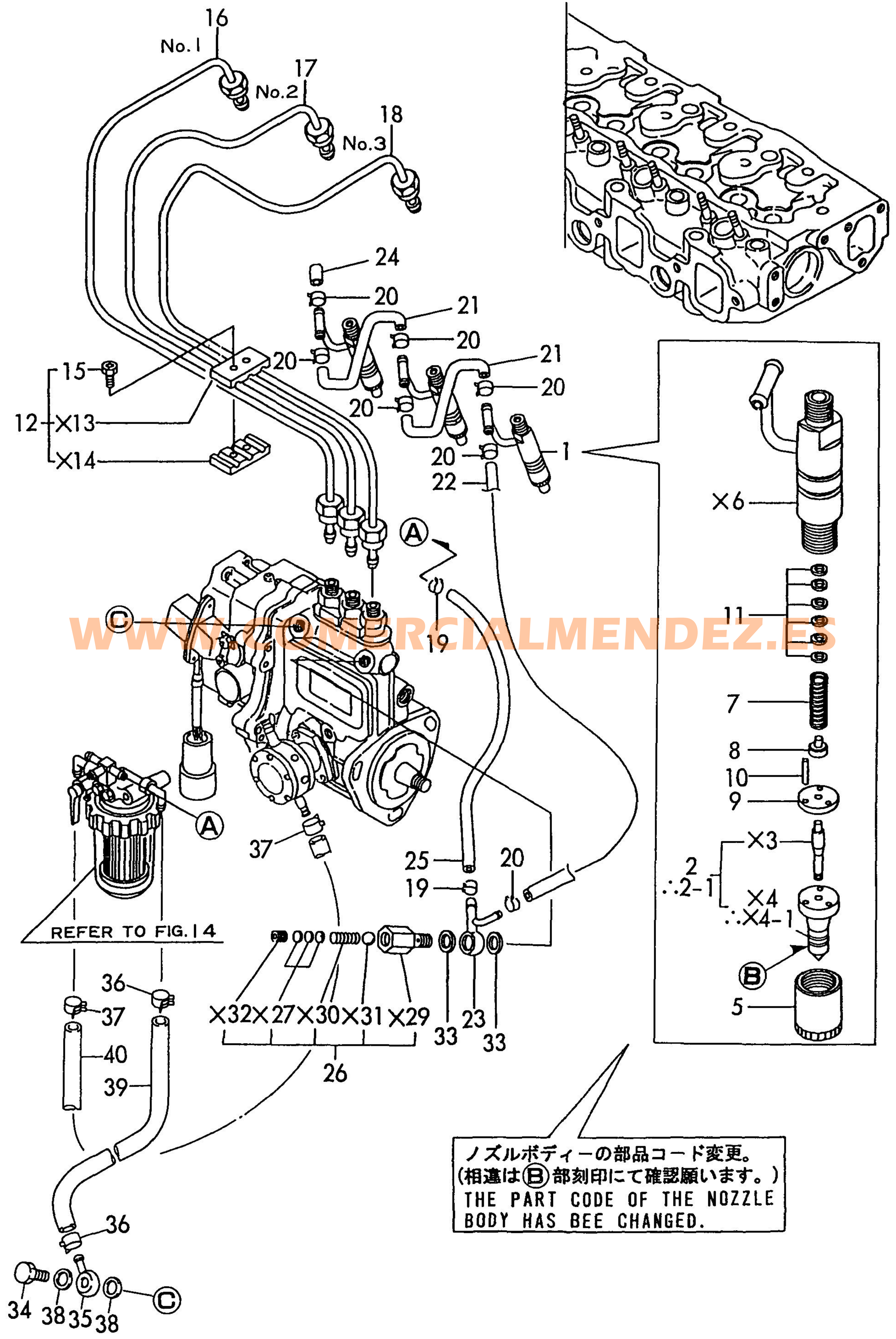
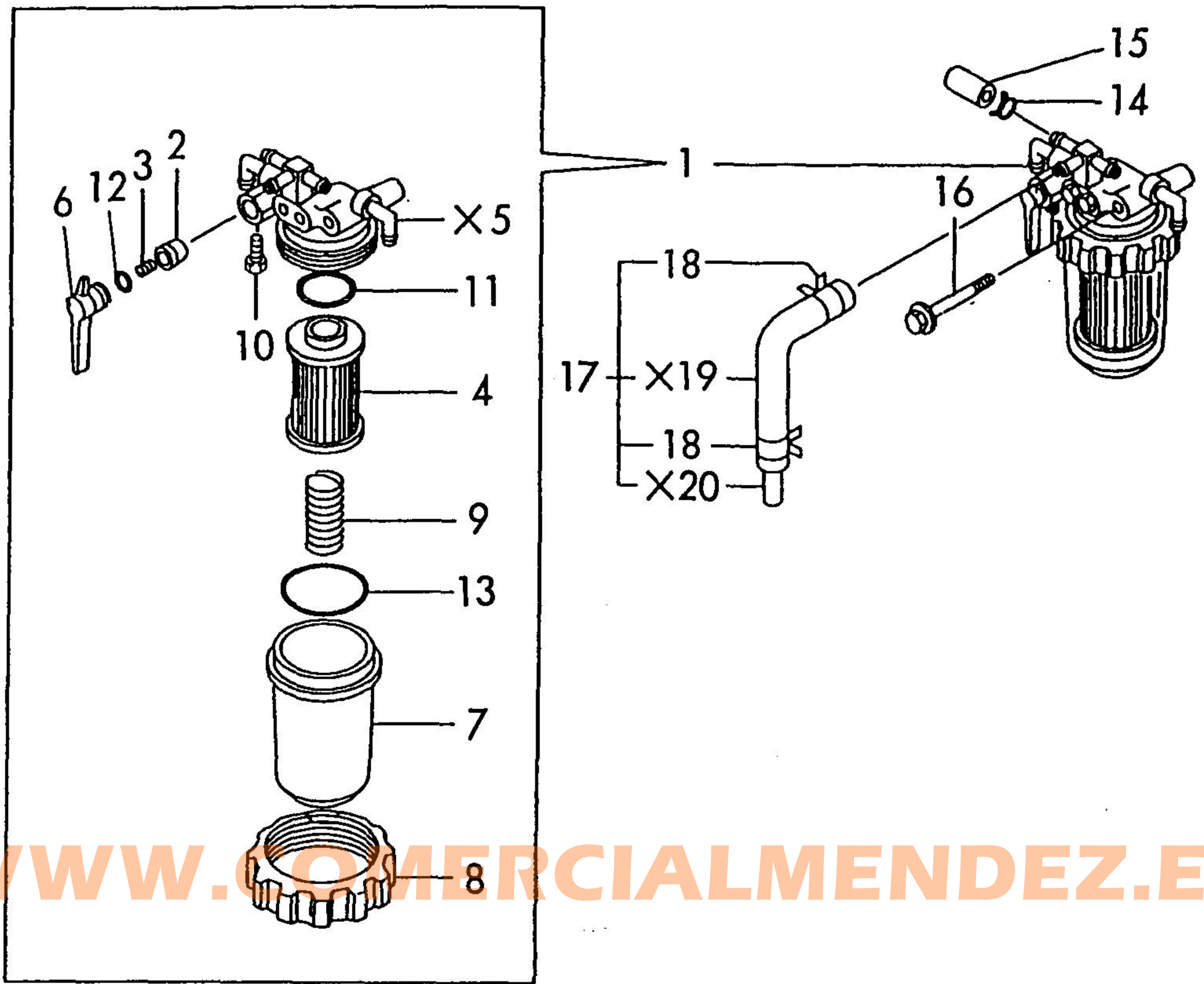

Fig. **14** FUEL STRAINER & OIL/WATER SEPARATOR



WWW.COMERCIALMENDEZ.ES

